

# PRECOR®

RESOLUTE™ MULTI-STATIONS



## RESOLUTE™ MULTI-STATIONS

The contemporary, sleek design blends durability with modularity, providing you with the versatility and functionality necessary to attract and satisfy the ever-changing exerciser over the long term.

### Dimensions (LxWxH)

153 x 95 x 94 in (388 x 243 x 237 cm)

**Weight** 1310 lb (594 kg)\*

\*Weight based on a standard weight stack



# ANCHOR YOUR FACILITY

Creating the right atmosphere for your facility is essential. The Resolute Multi-Stations features a contemporary design supporting Precor strength and cardio products. Its versatile configurations attract first-timers and seasoned lifters, offering a boundless array of workout possibilities.



## Dimensions (LxWxH)

213 x 153 x 94 in (542 x 388 x 237 cm)

**Weight** 1587 lb (720 kg)\*

\*Weight based on a standard weight stack

# HASSLE-FREE WORKOUT EXPERIENCE

Resolute Multi-Stations are the first to provide a dedicated spot to securely position a phone for optimal viewing of fitness apps while training. With an integrated 5-lb add-on weight and ample storage options, exercisers stay focused on their workout and not searching for accessories.

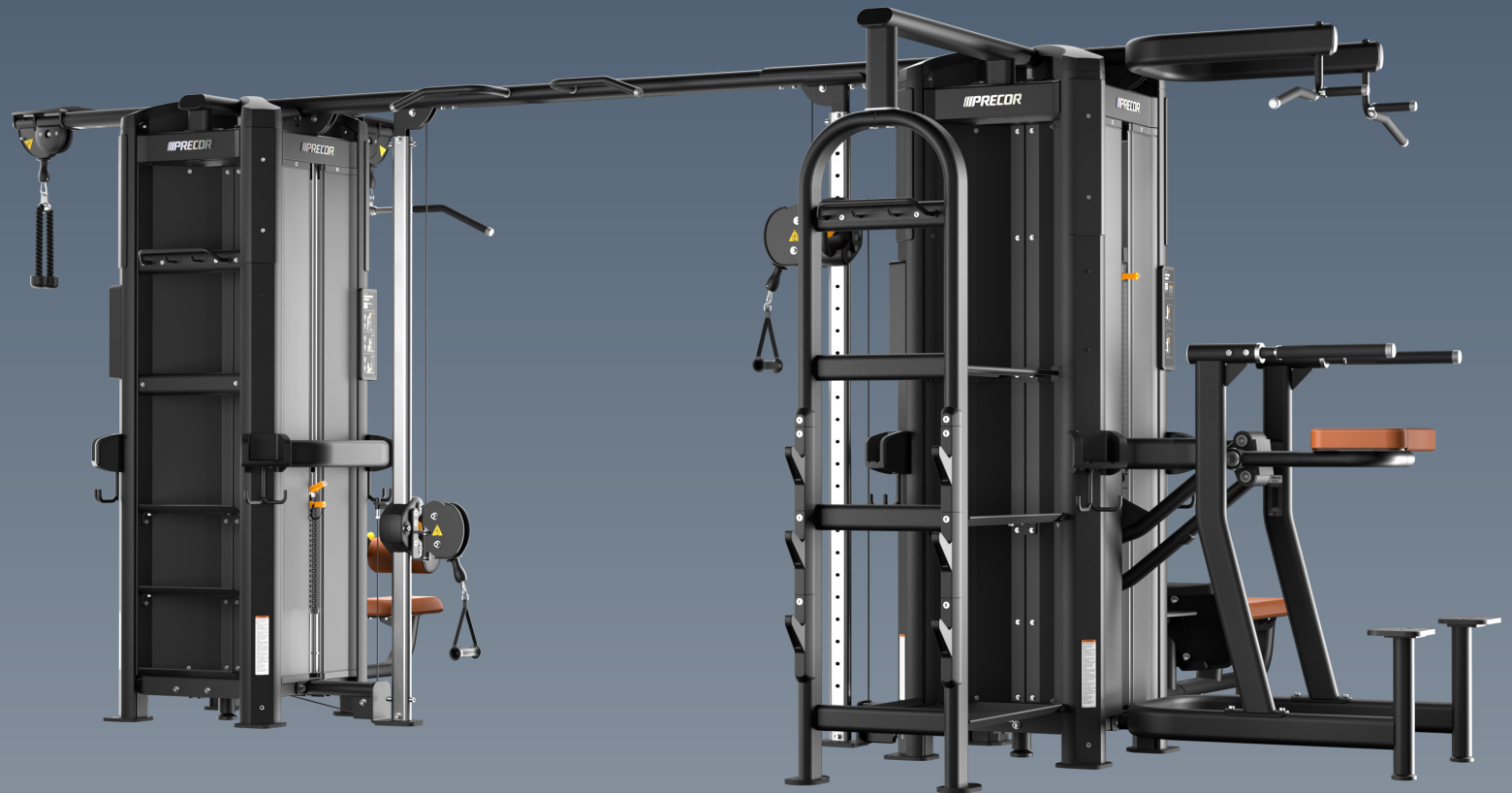

## Dimensions (LxWxH)

290 x 155 x 94 in (738 x 394 x 237 cm)

**Weight** 1885 lb (855 kg)\*

\*Weight based on a standard weight stack



**Dimensions (LxWxH)**

68 x 58 x 94 in (148 x 135 x 237 cm)

**Weight** 623 lb (283 kg)\*

\*Weight based on a standard weight stack

**Dimensions (LxWxH)**

68 x 58 x 94 in (148 x 135 x 237 cm)

**Weight** 429 lb (195 kg)\*

\*Weight based on a standard weight stack

Stations	Accessories	Standard	Heavy
Lat Pulldown	48 in Bent traditional lat pulldown handle	260 lb (118 kg)	340 lb (154 kg)
Low Row	A-frame style handle	260 lb (118 kg)	340 lb (154 kg)
Adjustable Pulley	Rubber coated pull handle and ankle cuff with velcro closure	220 lb (100 kg)	300 lb (136 kg)
Triceps Pushdown	Rope handle	220 lb (100 kg)	300 lb (136 kg)
Dip-Chin Assist		340 lb (154 kg)	

# COLOR OPTIONS

**Frame**



Black Pearl

Gloss Metallic Silver

Gloss White\*

• Custom frame colors are available, subject to minimum order quantities and extended lead times.

\* Additional lead time applies.

**Shroud**



Tungsten

• Custom shroud wraps are available at an additional cost.

**Upholstery**

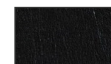

Black

**Additional Upholstery Options\*\***

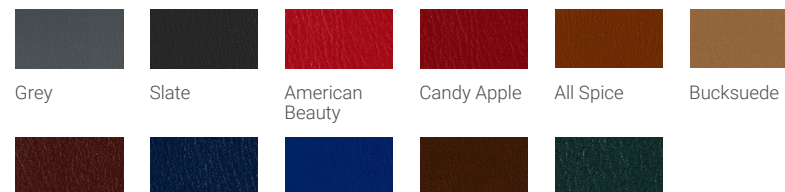

• Additional upholstery options may have longer lead times. Please contact a sales representative.  
• Colors may vary.

\*\* Additional lead time applies.

# FLEXIBLE CONFIGURATIONS

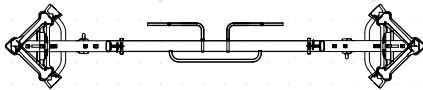

2 Stack Cable Crossover

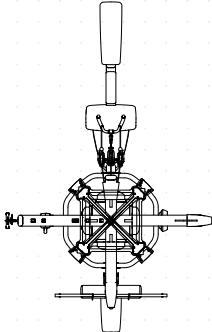

4 Stack

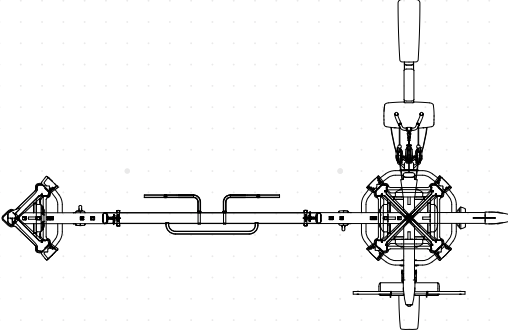

5 Stack

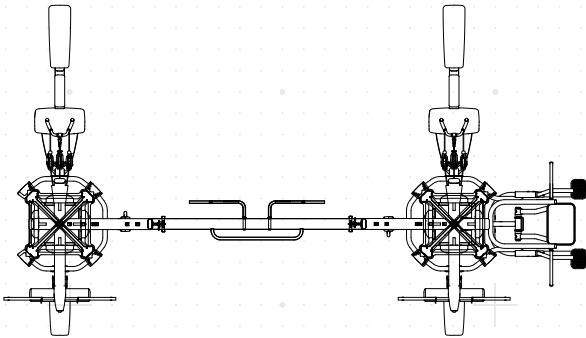

7 Stack

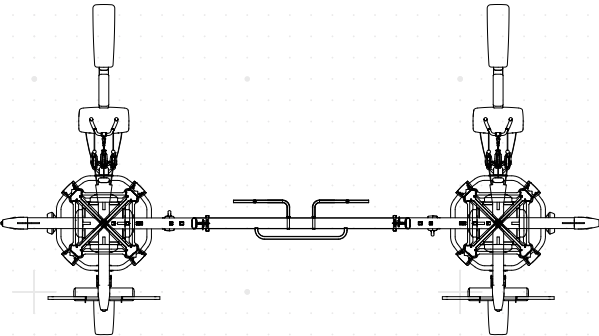

8 Stack

# MODULAR DESIGN THAT GIVES YOU CONTROL

Choose from a wide selection of stations and configure them to suit your facility's needs. As your facility grows, the modular design makes it easy to add or move stations as needed. The space-saving design ensures that there's plenty of room for lifters, without sacrificing space or usability.

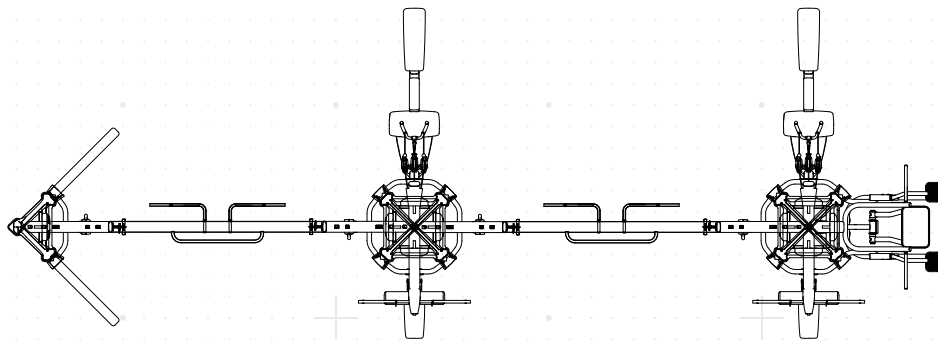

**9 Stack**

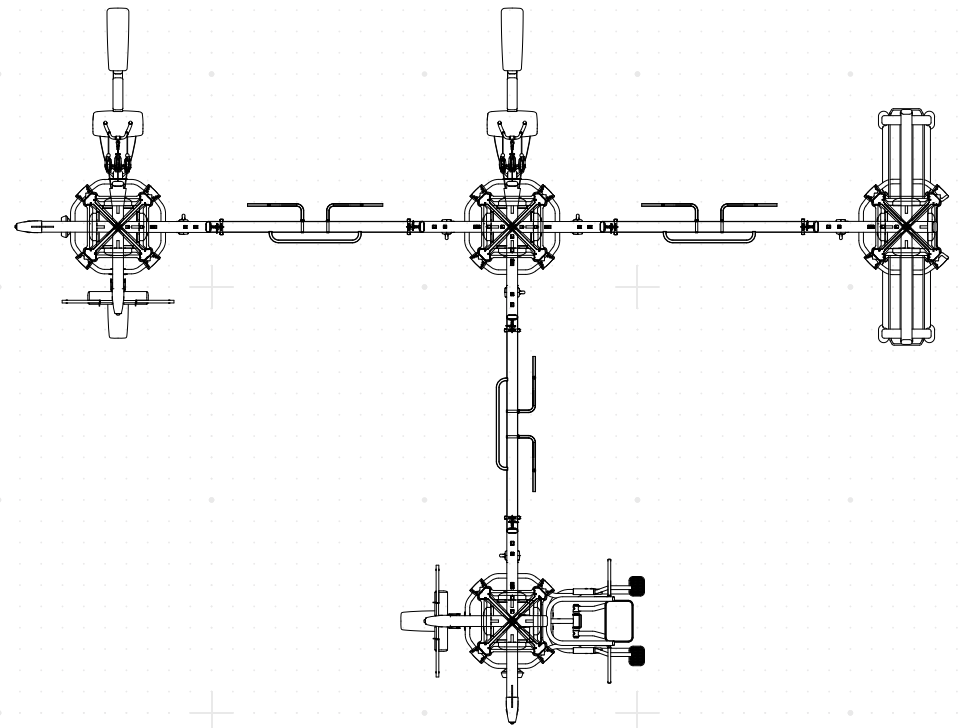

**13 Stack with Storage**



## **PRECOR USA**

Precor Incorporated 20031  
142nd Avenue NE  
Woodinville, WA  
98072-4002  
United States of America  
T: +1 425-486-9292  
F: +1 425-486-3856  
E: [commsls@precor.com](mailto:commsls@precor.com)  
[www.precor.com](http://www.precor.com)

**LEARN MORE AT: [PRECOR.COM/STRENGTH/FUNCTIONAL-SELECTORIZED](http://PRECOR.COM/STRENGTH/FUNCTIONAL-SELECTORIZED)**

©Precor Incorporated 2023. Precor reserves the right to make any changes without prior notice.  
Last Revision: August 2023.