

PRECOR[®]

COMMERCIAL CATALOG



CARDIO | CONNECTED FITNESS | STRENGTH

A modern gym with people using Precor UMAX treadmills and leg press machines. The gym is well-lit with large windows and wooden accents. Several people are visible in the background, some on treadmills and others on leg press machines. The foreground shows a woman in a red long-sleeve shirt and black shorts using a leg press machine, and another woman in a purple tank top and black leggings lying on a leg press machine. A woman in a blue tank top and white shorts is also visible on a leg press machine in the background. The overall atmosphere is active and professional.

PRECISION QUALITY PRODUCTS FOR THE WORLD

At Precor, we work hard to earn customer trust. That means putting the needs of you and your exercisers first—from product design and engineering to sales, installation, and support.

Discover the Precor difference and see why our fitness solutions are preferred by exercisers, trainers, facility operators, and business owners alike in over 100 countries.



CARDIO 8

Treadmills	10
Elliptical Fitness Crosstrainers (EFX®)	12
StairClimber	14
Adaptive Motion Trainers (AMT®)	16
Bikes	18
Indoor Cycling	20
Self-Powered Cardio	22

CONNECTED FITNESS 24

Consoles	26
Precor Connected Fitness	34
EGYM	38

STRENGTH 40

Resolute™ Strength Selectorized	42
Vitality™ Strength Selectorized	52
Discovery™ Strength Plate Loaded	62
Discovery™ Strength Benches & Racks	70
Vitality™ Strength Benches & Racks	78

Glutebuilder® Plate Loaded	86
Nike Strength	92
Resolute™ Strength Multi-Stations	98
Resolute™ Strength Dual Adjustable Pulley	104
Vitality™ Strength FTS Glide	106
Functional Training	108

WELLNESS 114

Saunas & Light Booth	116
Beds & Pods	118

SERVICES 120

Planning & Design	122
Financing & Leasing	122
Delivery & Installation	123
Service & Support	123
Movement Library	124

WHY PRECOR

Precor is the #1 choice in thousands of fitness facilities across 100+ countries.

YOU COME FIRST

Our extensive design and engineering process prioritizes people—operators, exercisers, and servicers. The result? Easy-to-manage equipment that empowers exercisers.

TRUSTED PARTNER

More than just a product supplier, we've provided full-service, total fitness solutions to customers across industries and continents for over 40 years.

GLOBAL SCALE, LOCAL TOUCH

Our network of sales, support, service, and distributor partners ensures you have the help you need—where and when you need it.





One-of-a-kind design, for over 40 years

Our legacy of “firsts” spans the first-ever ergonomic rowing machine and world’s premier elliptical—so you know we’ll keep your exercisers working out on the forefront of industry insight. With over 500 pending and issued patents worldwide, we sweat every detail to build products that are intuitive to use, easy to maintain, and deliver a low cost of ownership.





2012 Adaptive Motion Trainer with Open Stride



2014 800 Line Treadmill



2016 EFX® with Converging CrossRamp®



2019 Resolute™ Strength



2023 P94 & P84 Touchscreen Consoles



2024 Glutebuilder® Strength

2012 Discovery™ Strength



2016 P82 and P62 Touchscreen Consoles



2016 2017 700 & 600 Cardio Lines



2022 800 Line StairClimber



2023 Resolute™ Multi-Stations



PRECOR CARDIO

Proven designs, high-performance parts, and premium materials

- **MADE FOR MAKING MOVES**

Crafted for the sizes, shapes, speeds, and spaces of today.

- **FITNESS IS FOREMOST**

We start everything with one thing—provide the best fitness experience possible.

- **EASE OF USE**

Getting up for a 5 AM workout is hard. So we've made everything else easier for them and you.

- **RELIABILITY AND SIMPLICITY**

Made to make life simple with sturdy, user-friendly equipment that stands the test of time.

- **PERSONALIZATION**

Pick and choose a customized fitness experience fit for both you and your exercisers.





**>> VISIT
CARDIO**

CARDIO

Treadmills	10
Elliptical Fitness Crosstrainers	12
StairClimbers	14
Adaptive Motion Trainers®	16
Bikes	18
Indoor Cycling	20
Self-Powered Cardio	22

CARDIO

Treadmills

A lineup built to adapt to anyone who sets foot on them

- **INTEGRATED FOOTPLANT TECHNOLOGY™ (IFT™)**
Recognizes natural foot speeds and matches strides for a smooth experience.
- **GROUND EFFECTS® IMPACT CONTROL SYSTEM (GFX®)**
Our patented system that combines ideal cushioning, support and stability.
- **ACTIVE STATUS LIGHT**
Designed to let you know at a glance the operating condition of your treadmill.
- **QUIET & CLEANABLE**
Designed to make less noise and with fewer seams for an easy clean.



800 LINE

- Incline range -3 decline to 15% incline
- Speed 0.5 - 16 mph (0.8 - 25 kph) + Auto Stop™
- AC drive system and next-generation motor controller
- Active Status Light for maintenance status at a glance

Frame color options



Black Pearl



Storm Grey

[VISIT TREADMILLS »](#)





700 LINE

- Incline range 0 - 15% incline
- Speed 0.5 - 14 mph (0.8 - 23 kph) + Auto Stop™
- AC drive system and next-generation motor controller
- Active Status Light for maintenance status at a glance



600 LINE

- Incline range 0 - 15% incline
- Speed 0.5 - 12 mph (0.8 - 19 kph) + Auto Stop™
- High-efficiency 3 HP AC motor

CONSOLE OPTIONS



P94

22 in (55.8 cm)



P84

16 in (40.6 cm)



P82

15 in (38.1 cm)



P62

10 in (25.4 cm)



P31

CARDIO

Ellipticals

Machines made to mimic
the most natural movement

- **EXCLUSIVE CONVERGING CROSSRAMP® TECHNOLOGY**

Mimics the natural converging path of motion while walking or running.

- **ELLIPTICAL EXPERTS**

As the pioneers of the elliptical, we've been relentlessly improving its performance since 1995.

- **ACTIVE STATUS LIGHT**

Designed to let you know the operating condition of your elliptical at a glance.

- **PROTECT AND MAINTAIN**

Easy to clean and maintain with a covered ramp, frame and pivot joints.



800 LINE MOVING HANDLEBARS

- A premium experience with all the bells and whistles
- Converging CrossRamp® is adjustable between 10 and 35 degrees
- Moving handlebars for a total body workout
- Active Status Light for maintenance status at a glance

Frame color options



Black Pearl



Storm Grey

[VISIT ELLIPTICALS »](#)





800 LINE FIXED HANDLEBARS

- A premium experience with all the bells and whistles
- Converging CrossRamp® is adjustable between 10 and 35 degrees
- Fixed handlebars for a lower body workout
- Active Status Light for maintenance status at a glance



600 LINE MOVING HANDLEBARS

- All the essentials at a value price
- CrossRamp® is adjustable between 10 and 35 degrees
- Moving handlebars for a total body workout

CONSOLE OPTIONS



P84

16 in (40.6 cm)



P82

15 in (38.1 cm)



P62

10 in (25.4 cm)



P31

CARDIO

StairClimber

The trusted choice for the fastest-growing cardio category

- **THE ONE YOU CAN TRUST**

Precision components and rigorous testing ensures dependability for the long haul.

- **BEST OWNERSHIP EXPERIENCE**

Exceeds industry standards with innovative features, minimal maintenance and ease of service.

- **FITS AND PERFORMS FOR ALL**

Encourages exercisers to step with confidence while engaging them with effective workouts and media.

- **LOST ITEM SLIDE**

Earbuds fell into the gap? A unique design returns personal items without the hassle.

[VISIT STAIRCLIMBERS »](#)

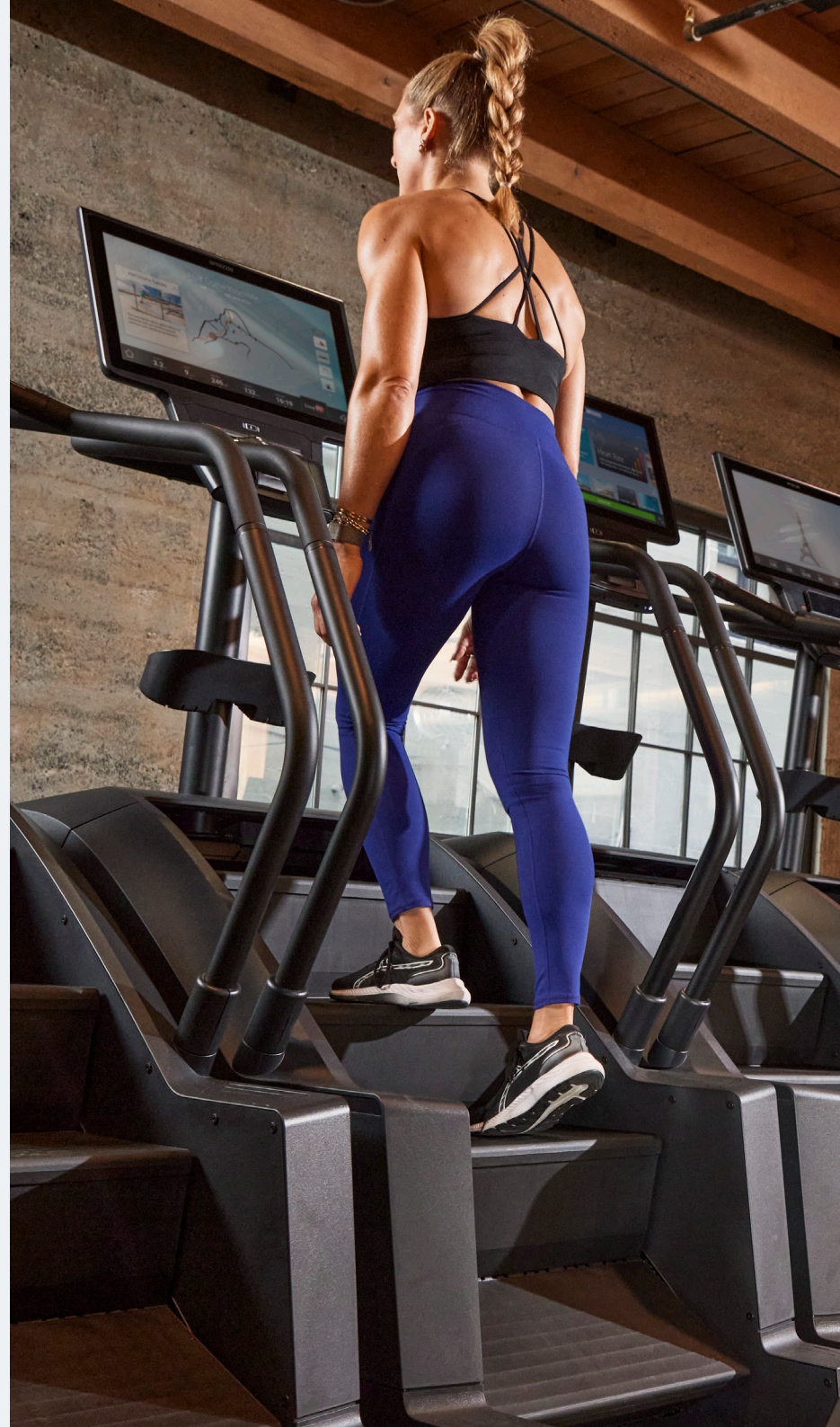



800 LINE

- Large step area
- Dedicated HIIT and geographical milestones workouts
- Low maintenance step chain
- Active Status Light
- Recommended ceiling height 9 ft 9 in (3 m)

Frame color options



Black Pearl



Storm Grey

CONSOLE OPTIONS



P94

22 in (55.8 cm)



P84

16 in (40.6 cm)



P31

CARDIO

Adaptive Motion Trainer[®]

The only one of its kind that lets you climb, jog, or run without impact

- **OPEN STRIDE™ & DYNAMIC ADJUSTABLE STRIDE LENGTH**

Two features. Four movements. Infinite number of workouts.

- **FULL BODY, BETTER RESULTS**

Push and pull handlebars work the upper body for a total body workout.

- **NEXT-LEVEL CARDIO FITNESS**

AMT workouts drive a high calorie burn.

- **SAVE ON SPACE, AND COST OF OWNERSHIP**

Pack a big punch without the power draw.

[VISIT ADAPTIVE MOTION TRAINERS »](#)





800 LINE

- An infinite number of workout options
- Adaptive stride length 0 to 36 in / 0 to 91 cm
- Adjustable stride height 5 levels, 6.8 to 10 in / 17 to 25 cm
- 20 resistance levels

Frame color options



Black Pearl



Storm Grey

CONSOLE OPTIONS



P84

16 in (40.6 cm)



P82

15 in (38.1 cm)



P62

10 in (25.4 cm)



P31

CARDIO

Bikes

Easy-to-use fitness staples,
for smooth rides every time

- **STURDY AND SMOOTH**

The well-built, durable frame makes for a stable and comfortable ride.

- **QUIET AND CLEANABLE**

Crafted to minimize noise and designed with fewer seams for effortless cleaning.

- **PEAK COMFORT**

Extra wide seats, ventilated seat backs, and thoughtful touchpoints accommodate all body types.

- **CYCLING ERGONOMICS**

Engineered with minimal adjustments to quickly enable confident, smooth, and biomechanically correct rides.

[VISIT BIKES »](#)



800 LINE UPRIGHT

- Over-molded handlebars and comfortable saddle design
- Dual-sided pedals with integrated straps
- Simple one-handed seat adjustment
- 25 resistance levels



800 LINE RECUMBENT

- Step-through design
- Ventilated, suspension-mounted air flex seat back
- Dual-sided pedals with integrated straps
- Convenient, one-handed seat adjustment
- 25 resistance levels

Frame color options



Black Pearl



Storm Grey



CONSOLE OPTIONS



P84

16 in (40.6 cm)



P82

15 in (38.1 cm)



P62

10 in (25.4 cm)



P31



600 LINE UPRIGHT

- Over-molded handlebars and comfortable saddle design
- Over-sized pedals with integrated straps
- Familiar pop-pin seat adjustment



600 LINE RECUMBENT

- Step-through design
- Ventilated, suspension-mounted air flex seat back
- Over-sized pedals with integrated straps
- Simple single-handed seat adjustment

CARDIO

Stages Cycling

Elevate every riders' cycling experience, whether in studio or on the fitness floor

- **CYCLING-FOCUSED R&D**

Each bike is designed to withstand the rigors of exercise in top studios and fitness facilities.

- **PROVEN POWER METER**

Boasting overall wins in the Tour de France year after year, no other power meter is as tested or trusted.

- **EASY OWNERSHIP**

Innovative design offers a low-maintenance, coveted rider experience.

- **BACKED BY PRECOR**

Single source for sales, service, and education.

[VISIT STAGES CYCLING »](#)





SC3

- Fully featured premium indoor cycling, features Stages Power Meter and SIC2 Console.
- Lightweight and ergonomic bike features an aluminum frame and magnetic resistance for durability and ease of use.
- Seamlessly and wirelessly connects to your technology via Bluetooth® and ANT+™



SC2

- Designed for boutique studios, setting the standard for rhythm cycling.
- Features an aluminum frame and magnetic resistance, making it both modern and easy to maintain.
- Improve the riding experience with accessories, such as the Stages Power Meter.

SC1

- Ideal for facilities that value quality and affordability.
- A proven design with magnetic resistance, boasting a solid steel frame with a focus on stability and function.
- Upgradable with the Stages Power meter and a standard battery-powered console.



CARDIO

Assault Fitness

Run, row, and bike like an elite.

- **COMMERCIAL DURABILITY**

The well-built, durable frames make for a stable and comfortable ride.

- **LOW IMPACT MEETS HIGH INTENSITY**

Engineered to deliver maximum output with less impact and stress on the body.

- **RESULTS-DRIVEN**

High contrast LCD offers immediate feedback, diverse workouts, and Bluetooth connectivity.

[VISIT SELF-POWERED CARDIO »](#)



SELF-POWERED CARDIO



ASSAULT RUNNER ELITE

- Non-motorized design
- Easy-to-read LCD console
- Nine preset training programs
- Dual water bottle holder
- Integrated handle and transport wheels



ASSAULT ROWER ELITE

- Easy-to-read LCD console
- Comfortable ergonomic seat
- Multi-grip handle
- Integrated handle and transport wheels
- Dual stage chain and belt drive



ASSAULT BIKE ELITE

- Easy-to-read LCD console
- Bluetooth and ANT connectivity
- Large, ergonomic seat with multi-adjustments
- Adjustable handlebars to fit all exercisers

CONNECTED FITNESS

Empower. Engage. Connect.

- **WORLD-CLASS SOFTWARE SOLUTIONS FOR YOUR FITNESS BUSINESS**

We design and deploy expert connected fitness products and services based on feedback from our global network of more than 143,000 connected Precor products and over 1.3 billion recorded workouts.

- **CONSOLES AND PARTNER INTEGRATIONS**

Precor offers multiple consoles and digital partner integrations to increase attraction, drive engagement, and improve your ownership experience.

- **ASSET MANAGEMENT**

Real-time equipment monitoring, remote software updates, and immediate access to the latest workouts and media offerings.

- **BOOST YOUR BRAND**

Elevate your brand with screensavers and custom experiences on our cardio consoles.

Not all features are available with all Precor Connected Fitness products.





>> VISIT
CONNECTED FITNESS

CONNECTED FITNESS

Consoles	26
Precor Connected Fitness	34
EGYM	38

CONNECTED FITNESS

P94 and P84 Touchscreen Consoles

Performance. Fitness. Entertainment.

- **PERFORMANCE**

Bright, high-definition 22" and 16" touchscreens with lightning-fast technology engage exercisers while keeping pace with their workouts.

- **FITNESS**

Over a decade of connected fitness experiences and over 1.3 billion workouts later, our latest consoles are built to inspire the next generation of cardio exercisers.

- **ENTERTAINMENT**

Wireless casting allows for immediate access to thousands of third-party apps. Exercisers always have their content, their way.

- **PEAK PERFORMANCE**

Designed to stand up to the demands of exercisers today and in the future. Our lightning-fast touchscreens with split-second response, have the power to deliver a premium fitness experience that is always at the forefront of innovation.

- **ENHANCED DISCOVERY**

Thoughtful user experience with compelling graphics and fitness-focused navigation surfaces new workouts and entertainment options, allowing exercisers to keep their workouts fresh and exciting.

- **INTEGRATED CONTENT SOLUTIONS**

Best-in-class visual graphics, exerciser insights, integration of Pluto TV streaming service, exclusive HIIT and Heart Rate workouts gives a cohesive fitness and media experience that motivates your exercisers and keeps them on track.

- **PRECORCAST™**

Exercisers enjoy the ultimate choice in workouts and entertainment without the need to sign-in; by casting content directly from their phone to the large display, they have access to thousands of fitness and media apps.

- **YOUR GYM, YOUR MESSAGE**

With customizable rotating images, the Screensaver Reel will help build your brand, allowing you to communicate to exercisers about facility activities and services, and keeping exercisers informed of new console features.

[VISIT P94 AND P84 TOUCHSCREEN CONSOLES »](#)



TOUCHSCREEN CONSOLES



P94 TOUCHSCREEN CONSOLE

- High-definition 22" touchscreen console
- Available on Treadmills and StairClimbers



P84 TOUCHSCREEN CONSOLE

- High-definition 16" touchscreen console
- Available on all Precor Cardio

CONNECTED FITNESS

PrecorCast

A better way to binge
and sweat

PrecorCast, Precor's proprietary Chromecast solution, allows exercisers to easily connect their phone to the console, enjoy their streaming app of choice, and feel secure knowing that when they end their workout, the device will remove all elements of their connection to the console.



[WATCH THE VIDEO »](#)





CONSOLES



P94

22 in (55.8 cm)



P84

16 in (40.6 cm)

CONNECTED FITNESS

Console Variety

Designed to be the ideal portal to Precor connected fitness, Precor consoles provide exercisers with a personalized and compelling workout experience that can be tracked, saved, and re-accessed. The clean and proven design of these consoles makes it easy for exercisers, whether new to Precor or familiar, to locate controls, inputs and adjustments. Whether it's the brilliant touchscreen or the easy-to-use LED intuitive interface, they will draw members deeper into their workout.

[VISIT P82/62 CONSOLES »](#)

[VISIT P31 CONSOLE »](#)

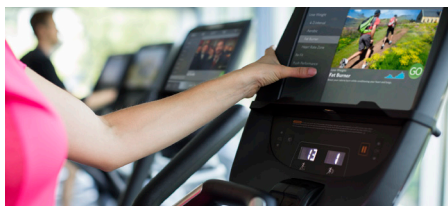

- **CAPACITIVE TOUCHSCREEN**

With a few simple swipes, exercisers select their workout, entertainment and get moving.

- **MOBILE DEVICE CHARGER**

All consoles feature a convenient mobile device charger to keep the tunes and entertainment flowing.

- **MOTION CONTROLS**

Large toggle-style controls are within arm's reach making adjustments to speed, resistance and ramps quick and easy.

- **READING RACK**

The perfect spot for phone and tablet viewing with the bonus of a hole for feeding charging cables to the mobile device charger.

- **FEATURED WORKOUT**

The touchscreen consoles promote new workouts everyday to prevent boredom and encourage variety.



P82 TOUCHSCREEN

The P82 is a 15-in (38.1 cm) capacitive touch screen console that seamlessly combines a fitness, media, and workout tracking experience into one simple design.



P62 TOUCHSCREEN

The P62 is a 10 in (25.7 cm) capacitive touchscreen console with a dual core processor that injects contemporary design and a premium networked fitness experience to the cardio floor.



P31 LED

P31 has a powerful combination of smarts and good looks to work harder for you, your services and your exercisers. Available with an optional personal viewing system, or an integrated audio receiver.

Console Options

Precor features innovative and reliable cardio equipment with consoles backed by tens of thousands of hours of testing in the field to ensure proven performance that facilities can count on. The “heads up” positioning of all the consoles encourages proper biomechanics and posture during the workout. We offer a choice of consoles to fit your facility to increase attraction, drive engagement, and improve your ownership experience.



P94 CONSOLE

The P94 is a 22-in (55.8cm) capacitive touch screen console is the next generation of cardio consoles that seamlessly combines the best combination of performance, fitness and entertainment.



P82 CONSOLE

The P82 is a 15-in (38.1 cm) capacitive touch screen console that seamlessly combines a fitness, media, and workout tracking experience into one simple design.



P84 CONSOLE

The P84 is a 16-in (40.6 cm) capacitive touch screen console redefines the cardio console experience, combining the best blend performance, fitness, and entertainment.



P62 CONSOLE

The P62 is a 10-in (25.7 cm) capacitive touch screen console that injects contemporary design and a premium networked fitness experience to the cardio floor.



P31 CONSOLE

P31 has a powerful combination of essential features and good looks to work harder for you, your servicers and your exercisers. Available with an optional personal viewing system, or an integrated audio receiver.



P94 CONSOLE



P84 CONSOLE



P82 CONSOLE



P62 CONSOLE



P31 CONSOLE

PRODUCT CONFIGURATIONS	Treadmill, StairClimber	Treadmill, StairClimber, Elliptical Fitness Crosstrainer (EFX®), Adaptive Motion Trainer (AMT®), Upright Bike, Recumbent Bike	Treadmill, StairClimber, Elliptical Fitness Crosstrainer (EFX®), Adaptive Motion Trainer (AMT®), Upright Bike, Recumbent Bike	Treadmill, StairClimber, Elliptical Fitness Crosstrainer (EFX®), Adaptive Motion Trainer (AMT®), Upright Bike, Recumbent Bike	Treadmill, StairClimber, Elliptical Fitness Crosstrainer (EFX®), Adaptive Motion Trainer (AMT®), Upright Bike, Recumbent Bike
DISPLAY TYPE	22-in (55.8 cm) LCD Capacitive Touchscreens	16-in (40.6 cm) LCD Capacitive Touchscreens	15-in (38.1 cm) LCD Capacitive Touchscreens	10-in (25.4 cm) LCD Capacitive Touchscreens	Advanced LED display
MOTION CONTROLS	•	•	•	•	•
LANGUAGES	English, Arabic, Chinese, Danish, Dutch, Finnish, French, German, Hebrew, Hindi, Italian, Japanese, Korean, Norwegian, Polish, Portuguese, Spanish, Swedish, Turkish, Russian, Welsh	English, Arabic, Chinese, Danish, Dutch, Finnish, French, German, Hebrew, Hindi, Italian, Japanese, Korean, Norwegian, Polish, Portuguese, Spanish, Swedish, Turkish, Russian, Welsh	English, Arabic, Chinese, Danish, Dutch, Finnish, French, German, Hindi, Italian, Japanese, Korean, Norwegian, Polish, Portuguese, Spanish, Swedish, Turkish, Russian	English, Arabic, Chinese, Danish, Dutch, Finnish, French, German, Hindi, Italian, Japanese, Korean, Norwegian, Polish, Portuguese, Spanish, Swedish, Turkish, Russian	English, Dutch, German, Italian, Japanese, French, Polish, Portuguese, Russian, Spanish
PRECORCAST™	Optional	Optional	-	-	-
ASSET MANAGEMENT	Included with PBS	Included with PBS	Included with PBS	Included with PBS	-
PERSONAL VIEWING SYSTEM	Embedded	Embedded	Embedded	Embedded	Optional
MOBILE DEVICE CHARGER	Wireless	Wireless	Wired	Wired	Wired

• Standard - Not offered

CONNECTED FITNESS

Precor Connected Fitness

Media and metrics to keep your exercisers motivated and you up to speed

Better data is better for your business. We design and deploy expert connected fitness products and services based on feedback from our global network of more than 143,000 connected Precor products and over 1.2 billion recorded workouts. Depending on your business priorities, exerciser expectations, and budget, you'll find flexible products and services to accelerate your vision.





Delight your exercisers to drive retention

- **KEEP YOUR EXERCISERS ENGAGED**

Remote software updates and immediate access to the latest workouts and media offerings ensure that your exercisers enjoy the most up-to-date fitness experience possible.

- **STRENGTHEN YOUR CONNECTION**

Stay connected and keep in touch with your exercisers to keep them motivated. You can even customize the interface to match your branding.

- **INTERFACE WITH INTELLIGENCE**

Use equipment data to make informed investment decisions, optimize equipment rotation, and proactively address maintenance issues to minimize downtime.

CONNECTED FITNESS

Tools to Grow Your Business

Incorporating technology and digital services into your gym can help you build your brand, engage with your members, and strengthen your gym community. And we make it simple. When you connect the Precor Touchscreen consoles to the internet, you've got connected fitness. Leverage the full suite of tools to customize the console experience and directly communicate with your exercisers to increase attraction, improve retention, drive revenue, and optimize your cardio equipment management.

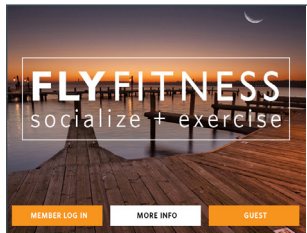

CUSTOMIZABLE WALK-UP SCREEN

Extend the presence of your brand to the cardio floor with a high-impact, customizable screen. Add a button that leads to content about your facility to keep in touch with your exercisers.

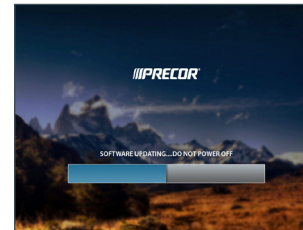

AUTOMATIC SOFTWARE UPDATES

All networked Precor touchscreen consoles receive automatic software updates, refreshed content, and new features—at no expense, and without any action required by you.

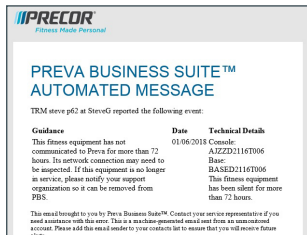

ASSET MANAGEMENT ALERTS

Choose from immediate alerts or weekly summaries to keep in touch with your Precor cardio equipment. Our system continually watches the alerts, preventing duplicates and an overflow of repeats.



CUSTOM BRANDING

Elevate your brand with the Screensaver Reel and customized experiences on our cardio consoles. Consider promoting your services, special offers, or operational information, such as changes in hours.

ID	Name	Age	Sex	Start Date	End Date	Start Time	End Time	Distance	Calories	Heart Rate	Zone
1000000001	John	30	M	2018-01-01	2018-01-01	06:00	07:00	2.00	500	150	Zone 1
1000000002	Jane	25	F	2018-01-01	2018-01-01	07:00	08:00	1.50	400	140	Zone 2
1000000003	Mike	45	M	2018-01-01	2018-01-01	08:00	09:00	3.00	800	160	Zone 3
1000000004	Sarah	35	F	2018-01-01	2018-01-01	09:00	10:00	2.50	650	155	Zone 2
1000000005	David	20	M	2018-01-01	2018-01-01	05:00	06:00	1.00	300	130	Zone 1
1000000006	Emily	30	F	2018-01-01	2018-01-01	06:30	07:30	2.00	550	145	Zone 2
1000000007	Chris	40	M	2018-01-01	2018-01-01	07:30	08:30	2.50	700	150	Zone 3
1000000008	Alex	28	M	2018-01-01	2018-01-01	08:30	09:30	1.50	450	140	Zone 2
1000000009	Olivia	35	F	2018-01-01	2018-01-01	09:30	10:30	2.00	600	150	Zone 3
1000000010	Noah	22	M	2018-01-01	2018-01-01	06:00	07:00	1.00	350	135	Zone 1

EXERCISER ACTIVITY REPORT

See the cardio activity of your Preva account holders with this simple online report. Great for supporting member challenges and contests, driving targeted communications, and measuring cardio preferences.

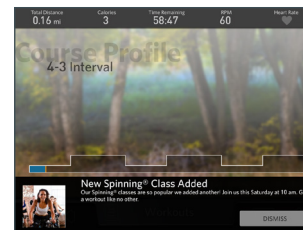

IN-WORKOUT MESSAGES

In-workout messages are a great way to stay connected to your cardio exercisers. Use them to promote your facility, events, specials, services, and schedules.



Streaming Media and Workouts

Free and embedded Pluto TV™, live TV options, and apps keep exercisers entertained while they sweat.



ENTERTAINMENT APPS*

Access personal audio and video entertainment apps, like Netflix® and YouTube® through the Precor touchscreen consoles. Workout finishes before the movies does? Exercisers can pick up right where they left off on their next workout or from any other personal device.

*Coming Early 2025

MORE MEDIA, LESS HASSLE

Enjoy an out-of-the-box TV experience on every console, powered by Pluto TV. Our seamless integration embeds Pluto TV directly into our channel guide, coexisting with your existing cable offerings, and providing a user experience that offers the same look and feel as live TV.



EGYM



Achieve more with EGYM and Precor

Personalized and progressive workouts for results-driven cardio sessions.

The Five Star integration of the EGYM cardio training system with Precor cardio equipment makes fitness training easier, more intuitive and motivating. Smart Workouts, an automated system with a brief fitness assessment, target exercisers with cardio programs that are personalized to each individual and incorporate gamification, making them fun and engaging.



BEST-IN-CLASS INTEGRATION

Lightning-fast Precor touchscreen consoles seamlessly integrate with EGYM technology to guide exercisers effectively to their personal endurance goals.



TAILOR-MADE FITNESS EXPERIENCE

Exercisers check in with regular fitness assessments to unlock new training workouts and prevent the onset of training plateaus.



FAST ACCESS TO PERSONAL WORKOUTS

One-touch access from a large tile on the Precor home screen promotes engagement to draw in your exercisers.



ENGAGING GAMIFICATION ELEMENTS

Exercisers stay motivated by earning activity points, which count toward a leaderboard. This playful element adds motivation, makes workouts more fun, and reinforces the community in your facility.

STRENGTH

Trusted by operators,
loved by exercisers

- **BRING OUT THE LIFTER IN EVERY BODY**

With a complete portfolio of selectorized, plate loaded, cable stations, and free weight options for your entire strength floor.

- **20+ YEARS IN STRENGTH**

Rooted in the famed Icarian® line, Precor strength products draw on a heritage of excellence and operator trust.

- **INNOVATION WHERE IT COUNTS**

We continuously evaluate and deliver new products and motions that will generate excitement and drive strength gains.

- **RELIABILITY AND DURABILITY**

Backed by our industry-best service, Precor strength products are built to last and perform.

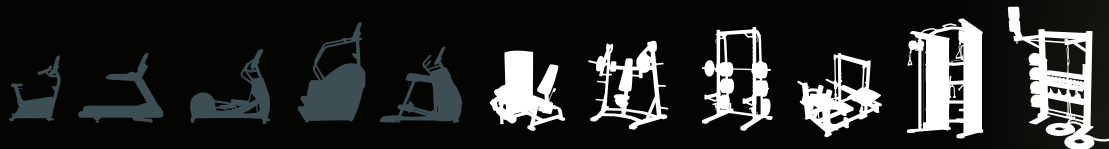





**VISIT
STRENGTH**

STRENGTH

Resolute™ Strength Selectorized	42
Vitality™ Strength Selectorized	52
Discovery™ Strength Plate Loaded	62
Discovery™ Strength Benches & Racks	70
Vitality™ Strength Benches & Racks	78
Glutebuilder® Plate Loaded	86
Nike Strength	92
Resolute™ Strength Multi-Stations	98
Resolute™ Strength Dual Adjustable Pulley	104
Vitality™ Strength FTS Glide	106
Functional Training	108
Wellness USA	114

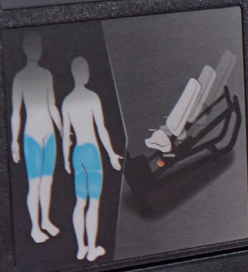

LEG PRESS





STRENGTH

Resolute™ Strength Selectorized

Proven biomechanics, movement paths,
and durability

Our 21-piece flagship strength line prioritizes proper biomechanics, natural strength paths and long-lasting quality. Each product is meticulously designed to ensure an optimal foundation for each lift, and the elegant design and proven durability keep exercisers coming back.

- **OPTIMIZED FOR THE LONG HAUL**

1.2 million cycles of testing so equipment lasts and looks great while doing it.

- **EASY TO USE**

Illustrated instructions and QR codes leading to teaching and tips from a fitness professional will inspire multiple workouts.

- **BUILT WITH EVERY BODY IN MIND**

Reimagined position and performance design optimizes function for all exercisers.

- **HIGH QUALITY, SAY "HELLO" TO PREMIUM DESIGN**

From grips to finishes, every detail is designed for lasting quality and ease of use.

[VISIT RESOLUTE SELECTORIZED»](#)

Resolute™ Strength Selectorized upper body



RSL0204
BICEPS CURL

Dimensions (LxWxH)
48 x 43 x 58 in (122 x 110 x 148 cm)
Weight 434 lb (197 kg)
Weight Stack 160 lb (73 kg)



RSL0208
TRICEPS EXTENSION

Dimensions (LxWxH)
48 x 43 x 58 in (122 x 110 x 148 cm)
Weight 460 lb (209 kg)
Weight Stack 160 lb (73 kg)



RSL0215
SEATED DIP

Dimensions (LxWxH)
55 x 48 x 58 in (140 x 122 x 148 cm)
Weight 585 lb (266 kg)
Weight Stack 240 lb (109 kg)

RESOLUTE™ STRENGTH SELECTORIZED - UPPER BODY



RSL0310
DIVERGING SEATED ROW

Dimensions (LxWxH)
63 x 55 x 58 in (160 x 140 x 148 cm)
Weight 616 lb (280 kg)
Weight Stack 240 lb (109 kg)



RSL0314
DIVERGING LAT PULLDOWN

Dimensions (LxWxH)
57 x 50 x 81 in (145 x 127 x 206 cm)
Weight 585 lb (266 kg)
Weight Stack 240 lb (109 kg)



RSL0324
DIVERGING LOW ROW

Dimensions (LxWxH)
79 x 48 x 58 in (201 x 122 x 148 cm)
Weight 581 lb (264 kg)
Weight Stack 240 lb (109 kg)

Resolute™ Strength Selectorized upper/lower body



RSL0414
CONVERGING CHEST PRESS

Dimensions (LxWxH)
73 x 50 x 73 in (185 x 127 x 185 cm)
Weight 594 lb (269 kg)
Weight Stack 240 lb (109 kg)



RSL0504
LATERAL RAISE

Dimensions (LxWxH)
54 x 49 x 58 in (137 x 124 x 148 cm)
Weight 510 lb (231 kg)
Weight Stack 160 lb (73 kg)



RSL0505
REAR DELT / PEC FLY

Dimensions (LxWxH)
56 x 38 x 84 in (142 x 97 x 214 cm)
Weight 583 lb (265 kg)
Weight Stack 240 lb (109 kg)

RESOLUTE™ STRENGTH SELECTORIZED - UPPER/LOWER BODY



RSL0515
CONVERGING SHOULDER PRESS

Dimensions (LxWxH)
61 x 59 x 60 in (155 x 150 x 152 cm)
Weight 557 lb (253 kg)
Weight Stack 200 lb (91 kg)



RSL0618
GLUTE EXTENSION

Dimensions (LxWxH)
54 x 40 x 58 in (137 x 102 x 148 cm)
Weight 475 lb (216 kg)
Weight Stack 160 lb (73 kg)



RSL0623
SEATED CALF EXTENSION

Dimensions (LxWxH)
53 x 44 x 58 in (135 x 112 x 148 cm)
Weight 684 lb (311 kg)
Weight Stack 400 lb (182 kg)

Resolute™ Selectorized lower body



RSL0602
LEG PRESS

Dimensions (LxWxH)
77 x 48 x 58 in (196 x 122 x 148 cm)
Weight 826 lb (375 kg)
Weight Stack 400 lb (182 kg)



RSL0605
LEG EXTENSION

Dimensions (LxWxH)
61 x 50 x 58 in (155 x 127 x 148 cm)
Weight 616 lb (280 kg)
Weight Stack 240 lb (109 kg)



RSL0606
PRONE LEG CURL

Dimensions (LxWxH)
61 x 48 x 58 in (155 x 122 x 148 cm)
Weight 517 lb (235 kg)
Weight Stack 200 lb (91 kg)

RESOLUTE™ STRENGTH SELECTORIZED - LOWER BODY



RSL0619
SEATED LEG CURL

Dimensions (LxWxH)
63 x 48 x 58 in (160 x 122 x 148 cm)
Weight 609 lb (277 kg)
Weight Stack 240 lb (109 kg)



RSL0620
INNER THIGH

Dimensions (LxWxH)
71 x 30 x 58 in (180 x 76 x 148 cm)
Weight 570 lb (260 kg)
Weight Stack 200 lb (91 kg)



RSL0621
OUTER THIGH

Dimensions (LxWxH)
71 x 30 x 58 in (180 x 76 x 148 cm)
Weight 572 lb (260 kg)
Weight Stack 200 lb (91 kg)

Resolute™ Strength Selectorized core



RSL0315
ROTARY TORSO

Dimensions (LxWxH)
48 x 43 x 58 in (122 x 110 x 148 cm)
Weight 462 lb (210 kg)
Weight Stack 160 lb (73 kg)



RSL0313
BACK EXTENSION

Dimensions (LxWxH)
48 x 49 x 58 in (122 x 124 x 148 cm)
Weight 532 lb (242 kg)
Weight Stack 200 lb (91 kg)



RSL0714
AB CRUNCH

Dimensions (LxWxH)
51 x 47 x 58 in (130 x 119 x 147 cm)
Weight 559 lb (254 kg)
Weight Stack 160 lb (73 kg)



PRECOR

GLUTE EXTENSION





STRENGTH

Vitality™ Strength Selectorized

Luxe look, compact, and a variety of motion paths

Vitality Series Selectorized delivers on what's vital in a comprehensive conditioning circuit: workout variety, ease of use, and space efficiency for lower use fitness facilities.

- **DUALS DELIVER 2 FOR 1**

More than half of the Vitality line features dual exercise models.

- **UPSCALE CONTEMPORARY STYLING**

Easily blends with Vitality™ Benches & Racks and Resolute™ Strength Selectorized.

- **EASY TO USE**

Step-by-step placards are a helpful boost in unstaffed facilities.

- **DESIGNED WITH LIMITED SPACE IN MIND**

All models have a smaller footprint and low profile design.

[VISIT VITALITY SELECTORIZED»](#)

Vitality™ Strength Selectorized upper body



VSL001BP
CHEST PRESS

Dimensions (LxWxH)
39 x 52 x 69 in (99 x 132 x 176 cm)
Weight 464 lb (210 kg)
Weight Stack 240 lb (109 kg)



VSL015BP
REAR DELT / PEC FLY

Dimensions (LxWxH)
56 x 54 x 78 in (142 x 136 x 199 cm)
Weight 431 lb (196 kg)
Weight Stack 240 lb (109 kg)



VSL024BP
MULTI-PRESS

Dimensions (LxWxH)
72 x 58 x 69 in (182 x 148 x 175 cm)
Weight 568 lb (258 kg)
Weight Stack 240 lb (109 kg)

VITALITY™ STRENGTH SELECTORIZED - UPPER BODY



VSL025BP
BICEPS CURL / TRICEPS EXTENSION

Dimensions (LxWxH)

52 x 42 x 60 in (132 x 108 x 152 cm)

Weight 440 lb (200 kg)

Weight Stack 170 lb (78 kg)



VSL003BP
BICEPS CURL

Dimensions (LxWxH)

55 x 41 x 61 in (140 x 104 x 155 cm)

Weight 399 lb (181 kg)

Weight Stack 170 lb (78 kg)



VSL023BP
TRICEPS EXTENSION

Dimensions (LxWxH)

47 x 42 x 61 in (119 x 107 x 155 cm)

Weight 399 lb (181 kg)

Weight Stack 170 lb (78 kg)

Vitality™ Strength Selectorized upper body



VSL012BP
SHOULDER PRESS

Dimensions (LxWxH)

58 x 57 x 61 in (147 x 145 x 155 cm)

Weight 454 lb (206 kg)

Weight Stack 200 lb (91 kg)



VSL002BP
PULLDOWN

Dimensions (LxWxH)

56 x 51 x 88 in (142 x 130 x 224 cm)

Weight 433 lb (197 kg)

Weight Stack 220 lb (100 kg)

VITALITY™ STRENGTH SELECTORIZED - UPPER BODY



VSL19BP
SEATED ROW

Dimensions (LxWxH)

56 x 48 x 70 in (142 x 122 x 178 cm)

Weight 464 lb (211 kg)

Weight Stack 240 lb (109 kg)



VSL026BP
PULLDOWN / SEATED ROW

Dimensions (LxWxH)

79 x 52 x 87 in 200 x 131 x 220 cm)

Weight 495 lb (225 kg)

Weight Stack 220 lb (100 kg)

Vitality™ Strength Selectorized lower body



VSL005BP
LEG EXTENSION

Dimensions (LxWxH)
49 x 45 x 60 in (124 x 114 x 152 cm)
Weight 474 lb (215 kg)
Weight Stack 200 lb (91 kg)



VSL008BP
INNER / OUTER THIGH

Dimensions (LxWxH)
65 x 32 x 60 in (166 x 81 x 152 cm)
Weight 447 lb (203 kg)
Weight Stack 170 lb (77 kg)



VSL007BP
SEATED LEG CURL

Dimensions (LxWxH)
64 x 45 x 61 in (163 x 114 x 155 cm)
Weight 457 lb (208 kg)
Weight Stack 170 lb (78 kg)



VSL010BP
LEG PRESS / CALF EXTENSION

Dimensions (LxWxH)
76 x 44 x 69 in (193 x 111 x 175 cm)
Weight 631 lb (287 kg)
Weight Stack 295 lb (134 kg)



VSL027BP
LEG CURL / LEG EXTENSION

Dimensions (LxWxH)
55 x 45 x 60 in (140 x 113 x 152 cm)
Weight 574 lb (261 kg)
Weight Stack 240 lb (109 kg)

Vitality™ Strength Selectorized core



VSL014BP
ABDOMINAL

Dimensions (LxWxH)

57 x 38 x 60 in (144 x 97 x 152 cm)

Weight 480 lb (218 kg)

Weight Stack 200 lb (91 kg)



VSL011BP
BACK EXTENSION

Dimensions (LxWxH)

38 x 52 x 61 in (97 x 132 x 155 cm)

Weight 462 lb (210 kg)

Weight Stack 200 lb (91 kg)



VSL028BP
ABDOMINAL / BACK EXTENSION

Dimensions (LxWxH)

60 x 41 x 61 in (152 x 104 x 155 cm)

Weight 474 lb (215 kg)

Weight Stack 200 lb (91 kg)







PLATE LOADED

Discovery™ Strength Plate Loaded

Heavy duty performance meets
simple sophistication

- **BUILT FOR BETTER LIFTS**

Optimized movements, fast set-up, and high load capacity fit exercisers of all abilities.

- **LONG-LIVED PERFORMANCE**

Durable, solid frame built to perform for the long run and the most intense use.

- **SIMPLE SOPHISTICATION**

Premium finish, clean lines and open design make sure the look stands the test of time.

[VISIT DISCOVERY PLATE LOADED»](#)

Discovery™ Strength Plate Loaded



DPL0802
SMITH MACHINE

Dimensions (LxWxH)
58 x 84 x 91 in (148 x 213 x 231 cm)
Weight 414 lb (188 kg)
Start Weight 35 lb (16 kg)
Max. Lift Load Capacity 600 lb (272 kg)
Angle of Glide Path 11 degrees



DPL0603
HACK SQUAT

Dimensions (LxWxH)
82 x 64 x 58 in (208 x 162 x 148 cm)
Weight 485 lb (220 kg)
Start Weight 89 lb (40 kg)
Max. Lift Load Capacity 720 lb (327 kg)



DPL0601
ANGLED LEG PRESS

Dimensions (LxWxH)
96 x 57 x 57 in (244 x 145 x 145 cm)
Weight 595 lb (270 kg)
Start Weight 136 lb (62 kg)
Max. Lift Load Capacity 1080 lb (490 kg)



DPL0616
CALF RAISE

Dimensions (LxWxH)

59 x 30 x 40 in (150 x 76 x 102 cm)

Weight 165 lb (75 kg)

Start Weight 25 lb (11 kg)

Max. Lift Load Capacity 450 lb (204 kg)



DPL0624
SQUAT MACHINE

Dimensions (LxWxH)

91 x 67 x 61 in (231 x 170 x 155 cm)

Weight 498 lb (226 kg)

Start Weight 40 lb (18 kg)

Max. Lift Load Capacity 540 lb (245 kg)



DPL0560
LEG EXTENSION

Dimensions (LxWxH)

62 x 63 x 47 in (158 x 160 x 119 cm)

Weight 291 lb (132 kg)

Start Weight 13 lb (5.9 kg)

Max. Lift Load Capacity 450 lb (204 kg)

Discovery™ Strength Plate Loaded



DPL0561 LEG CURL

Dimensions (LxWxH)

48 x 66 x 55 in (122 x 167 x 140 cm)

Weight 331 lb (150 kg)

Start Weight 11 lb (5 kg)

Max. Lift Load Capacity 225 lb (102 kg)



DPL0520 BICEPS CURL

Dimensions (LxWxH)

53 x 38 x 48 in (135 x 97 x 122 cm)

Weight 258 lb (117 kg)

Start Weight 12 lb (5.4 kg)

Max. Lift Load Capacity 225 lb (102 kg)



DPL0521 SEATED DIP

Dimensions (LxWxH)

72 x 41 x 37 in (183 x 104 x 94 cm)

Weight 287 lb (130 kg)

Start Weight 8 lb (3.6 kg)

Max. Lift Load Capacity 360 lb (163 kg)



DPL0540
CHEST PRESS

Dimensions (LxWxH)
43 x 67 x 70 in (110 x 170 x 176 cm)
Weight 353 lb (160 kg)
Start Weight 12 lb (5.5 kg)
Max. Lift Load Capacity 450 lb (204 kg)



DPL0541
INCLINE PRESS

Dimensions (LxWxH)
43 x 78 x 71 in (110 x 198 x 180 cm)
Weight 346 lb (157 kg)
Start Weight 12 lb (5.5 kg)
Max. Lift Load Capacity 450 lb (204 kg)



DPL0550
SHOULDER PRESS

Dimensions (LxWxH)
57 x 61 x 62 in (145 x 155 x 157 cm)
Weight 310 lb (141 kg)
Start Weight 10 lb (4.5 kg)
Max. Lift Load Capacity 360 lb (163 kg)

Discovery™ Strength Plate Loaded



DPL0305
PULLDOWN

Dimensions (LxWxH)
66 x 51 x 77 in (168 x 130 x 196 cm)
Weight 326 lb (148 kg)
Start Weight 5 lb (2.5 kg)
Max. Lift Load Capacity 450 lb (204 kg)



DPL0308
LOW ROW

Dimensions (LxWxH)
61 x 51 x 67 in (155 x 130 x 171 cm)
Weight 344 lb (156 kg)
Start Weight 15 lb (6.5 kg)
Max. Lift Load Capacity 450 lb (204 kg)



DPL0309
SEATED ROW

Dimensions (LxWxH)
58 x 50 x 49 in (148 x 127 x 124 cm)
Weight 340 lb (154 kg)
Start Weight 10 lb (4.5 kg)
Max. Lift Load Capacity 450 lb (204 kg)



DPL0311
INCLINE LEVER ROW

Dimensions (LxWxH)

75 x 39 x 48 in (190.5 x 99 x 122 cm)

Weight 191 lb (87 kg)

Start Weight 40 lb (18 kg)

Max. Lift Load Capacity 350 lb (159 kg)



STRENGTH

Discovery™ Strength Benches & Racks

The perfect tools for seasoned lifters and those new to strength training

- **BUILT FOR THE MASSES TO ADD MASS**

Approachable and easy for first-timers, but adaptive for the seasoned athlete.

- **LONG-LIVED PERFORMANCE**

Intelligent design and optimized durability, so you can make your strength purchase with confidence.

- **CONVENIENT STORAGE**

Thoughtful and functional built-in storage puts accessories within reach.



[VISIT DISCOVERY BENCHES & RACKS»](#)





DBR0610
POWER RACK

Dimensions (LxWxH)
83 x 63 x 98.5 in (211 x 160 x 250 cm)
Weight 613 lb (278 kg)
Weight Storage Horns 10
Max. Lift Load Capacity 800 lb (363 kg)
Max. Storage Weight 1800 lb (817 kg)



DBR0611
HALF RACK

Dimensions (LxWxH)
71 x 61 x 98.5 in (180 x 155 x 250 cm)
Weight 453 lb (205 kg)
Weight Storage Horns 10
Max. Lift Load Capacity 600 lb (272 kg)
Max. Storage Weight 1800 lb (817 kg)



**OPTIONAL POWER RACK &
HALF RACK ACCESSORIES**

- Band Peg Kit (pair)
- Combo Rack Connector Kit
- Side by Side Connector Kit
- Reverse Bar Catches
- Torso Trainer
- Dip Station (Power Rack only)
- Olympic Lifting Platforms and inserts (3.7 in / 9.4 cm thick, approximately 8 ft W x 6 ft D / 244 x 183 cm, excluding inserts). A custom logo option is available at an additional cost.

Discovery™ Strength Benches & Racks



DBR0608
OLYMPIC SQUAT RACK

Dimensions (LxWxH)
67 x 64 x 77 in (171 x 163 x 191 cm)
Weight 273 lb (124 kg)
Weight Storage Horns 8
Max. Lift Load Capacity 600 lb (273 kg)
Max. Storage Weight 1760 lb (798 kg)



DBR0408
OLYMPIC FLAT BENCH

Dimensions (LxWxH)
72 x 65 x 51 in (183 x 165 x 130 cm)
Weight 188 lb (85 kg)
Weight Storage Horns 8
Max. Lift Load Capacity 500 lb (227 kg)
Max. Storage Weight 1760 lb (798 kg)



DBR0410
OLYMPIC INCLINE BENCH

Dimensions (LxWxH)
79 x 65 x 55 in (201 x 165 x 140 cm)
Weight 221 lb (100 kg)
Weight Storage Horns 8
Max. Lift Load Capacity 500 lb (227 kg)
Max. Storage Weight 1760 lb (798 kg)



DBR0411
OLYMPIC DECLINE BENCH

Dimensions (LxWxH)
83 x 65 x 51 in / 211 x 165 x 130 cm
Weight 217 lb (98 kg)
Weight Storage Horns 8
Max. Lift Load Capacity 500 lb (227 kg)
Max. Storage Weight 1760 lb (798 kg)



DBR0507
OLYMPIC SHOULDER PRESS BENCH

Dimensions (LxWxH)
53 x 64 x 72 in (135 x 162 x 183 cm)
Weight 301 lb (136.3 kg)
Weight Storage Horns 8
Max. Lift Load Capacity 500 lb (227 kg)
Max. Storage Weight 880 lb (400 kg)



DBR0101
FLAT BENCH

Dimensions (LxWxH)
52 x 30 x 15 in (132 x 76 x 38 cm)
Weight 64 lb (29 kg)
Max. Lift Load Capacity 400 lb (182 kg)

Discovery™ Strength Benches & Racks



DBR0119
MULTI-ADJUSTABLE BENCH

Dimensions (LxWxH)

55 x 30 x 18 in (140 x 76 x 46 cm)

Weight 106 lb (48 kg)

Max. Lift Load Capacity 400 lb (182 kg)



DBR0116
MULTI-PURPOSE BENCH

Dimensions (LxWxH)

49 x 30 x 33 in (125 x 76 x 84 cm)

Weight 82 lb (37 kg)

Max. Lift Load Capacity 400 lb (182 kg)



DBR0113
ADJUSTABLE DECLINE BENCH

Dimensions (LxWxH)

58 x 30 x 44 in (147 x 76 x 112 cm)

Weight 126 lb (57 kg)

Max. Lift Load Capacity 400 lb (182 kg)



DBR0202
PREACHER CURL BENCH

Dimensions (LxWxH)
42 x 37 x 36 in (107 x 94 x 91 cm)
Weight 128 lb (58 kg)
Max. Lift Load Capacity 400 lb (182 kg)



DBR0312
BACK EXTENSION

Dimensions (LxWxH)
53 x 40 x 30 in (135 x 102 x 76 cm)
Weight 141 lb (64 kg)
Max. Lift Load Capacity 100 lb (45.4 kg)



DBR0702
VERTICAL KNEE-UP

Dimensions (LxWxH)
27 x 43 x 66 in (69 x 109 x 168 cm)
Weight 201 lb (91 kg)
Max. Lift Load Capacity 100 lb (45.4 kg)

Discovery™ Strength Benches & Racks



DBR0808
BARBELL RACK

Dimensions (LxWxH)

41 x 34 x 59 in (104 x 86 x 150 cm)

Weight 183 lb (83 kg)

Max. Storage Weight 800 lb (363 kg)



DBR0818
HANDLE RACK

Dimensions (LxWxH)

37 x 26 x 42 in (94 x 66 x 107 cm)

Weight 128 lb (58 kg)

Max. Storage Weight 500 lb (227 kg)



DBR0817
WEIGHT PLATE TREE

Dimensions (LxWxH)

26 x 30 x 47 in (65 x 75 x 119 cm)

Weight 77 lb (35 kg)

Weight Storage Horns 6

Max. Storage Weight 1000 lb (454 kg)



DBR0813
BEAUTY BELL RACK

Dimensions (LxWxH)

51 x 30 x 41 in (130 x 76 x 104 cm)

Weight 205 lb (93 kg)

Max. Storage Weight 400 lb (181.5 kg)



DBR0814
3 TIER, 10 PAIR DUMBBELL RACK

Dimensions (LxWxH)

51 x 30 x 41 in (130 x 76 x 104 cm)

Weight 214 lb (97 kg)

Max. Storage Weight 500 lb (227 kg)



DBR0812
2 TIER, 10 PAIR DUMBBELL RACK

Dimensions (LxWxH)

87 x 28 x 32 in (221 x 71 x 81 cm)

Weight 207 lb (94 kg)

Max. Storage Weight 1600 lb (726 kg)



DBR0815
3 TIER, 15 PAIR DUMBBELL RACK

Dimensions (LxWxH)

87 x 30 x 42 in (221 x 76 x 107 cm)

Weight 300 lb (136 kg)

Max. Storage Weight 1200 lb (544 kg)

STRENGTH

Vitality™ Strength Benches & Racks

Offers great exercise variety for smaller spaces

- **MAKE A STRONG FIRST IMPRESSION**

High-quality materials and construction deliver a premium appearance for years to come.

- **MEETS THE PREMIUM STANDARD**

Tested and warrantied to the same standards as our premium strength lines.

- **DESIGNED TO COMPLEMENT**

Mixes and matches with FTS Glide, Resolute™ Strength, and Discovery™ Series.

[VISIT VITALITY BENCHES & RACKS»](#)





VBR6801
SMITH MACHINE

Dimensions (LxWxH)
58 x 84 x 91 in (148 x 213 x 231 cm)
Weight 185 lb (408 kg)
Max. Lift Load Capacity 265 lb (120 kg)



VBR6101
FLAT BENCH

Dimensions (LxWxH)
52 x 30 x 16 in (131 x 75 x 41 cm)
Weight 46 lb (21 kg)
Max. Lift Load Capacity 200 lb (91 kg)



VBR6113
DECLINE AB BENCH

Dimensions (LxWxH)
59 x 30 x 40 in (151 x 75 x 101 cm)
Weight 108 lb (49 kg)
Max. Lift Load Capacity 200 lb (91 kg)

Vitality™ Strength Benches & Racks



VBR6116
UTILITY BENCH

Dimensions (LxWxH)

33 x 30 x 32 in (85 x 75 x 83 cm)

Weight 37 lb (17 kg)

Max. Storage Weight 200 lb (91 kg)



VBR6117
FLAT INCLINE DECLINE BENCH

Dimensions (LxWxH)

54 x 30 x 18 in (137 x 76 x 46 cm)

Weight 82 lb (37 kg)

Max. Lift Load Capacity 200 lb (91 kg)



VBR6202
PREACHER CURL BENCH

Dimensions (LxWxH)

52 x 39 x 30 in (133 x 99 x 75 cm)

Weight 101 lb (46 kg)

Max. Storage Weight 200 lb (91 kg)



VBR6312
BACK EXTENSION

Dimensions (LxWxH)

45 x 43 x 85 in (115 x 110 x 215 cm)

Weight 218 lb (99 kg)

Max. Storage Weight 200 lb (91 kg)



VBR6702
VERTICAL KNEE PLUS

Dimensions (LxWxH)
41 x 33 x 58 in (104 x 828 x 147 cm)
Weight 148 lb (67 kg)
Max. Storage Weight 200 lb (91 kg)



VBR6804
3 TIER, 10 PAIR FLAT DUMBBELL RACK

Dimensions (LxWxH)
48 x 30 x 39 in (122 x 76 x 99 cm)
Weight 145 lb (65 kg)
Max. Storage Weight 550 lb (249 kg)



VBR6805
3 TIER, 15 PAIR FLAT DUMBBELL RACK

Dimensions (LxWxH)
80 x 30 x 39 in (203 x 76 x 99 cm)
Weight 212 lb (96 kg)
Max. Storage Weight 1200 lb (544 kg)

Vitality™ Strength Benches & Racks



VBR6808
BARBELL RACK

Dimensions (LxWxH)

46 x 37 x 37 in (117 x 93 x 93 cm)

Weight 86 lb (39 kg)

Max. Storage Weight 425 lb (193 kg)



VBR6809
VERTICAL 8 PAIR DUMBBELL RACK

Dimensions (LxWxH)

25 x 31 x 56 in (64 x 79 x 141 cm)

Weight 88 lb (40 kg)

Max. Storage Weight 360 lb (163 kg)



VBR6814
3 TIER, 10 PAIR SADDLE DUMBBELL RACK

Dimensions (LxWxH)

56 x 30 x 40 in (142 x 76 x 102 cm)

Weight 139 lb (63 kg)

Max. Storage Weight 550 lb (249 kg)



VBR6815
3 TIER, 15 PAIR SADDLE DUMBBELL RACK

Dimensions (LxWxH)

82 x 30 x 40 in (208 x 76 x 102 cm)

Weight 178 lb (81 kg)

Max. Storage Weight 1200 lb (544 kg)



VBR6820B
2 TIER, HORIZONTAL KETTLEBELL SHELF

Dimensions (LxWxH)

48 x 30 x 23 in (122 x 76 x 58 cm)

Weight 95 lb (43 kg)

Max. Storage Weight 560 lb (255 kg)



VBR6820
UTILITY AND ACCESSORY STORAGE*

Dimensions (LxWxH)

65 x 30 x 92 in (165 x 76 x 234 cm)

Weight 181 lb (82 kg)

Max. Storage Weight 710 lb (322 kg)

*Unit includes kettlebell shelves



CORE AND STRETCHING

Strengthen and stretch off the floor

AB-X

The unique “floating pivot point” design of the Ab-X creates the ideal “crunch” movement while the contoured pads reduce stress to neck and shoulders.

STRETCHTRAINER™

The StretchTrainer™ allows exercisers to achieve deep, supportive stretches for their back, hips, shoulders, and legs, promoting faster recovery and improved flexibility.

[VISIT CORE AND STRETCHING »](#)

VITALITY™ STRENGTH BENCHES & RACKS



VBR6100
AB-X

Dimensions (LxWxH)
52 x 26 x 38 in (132 x 66 x 97 cm)
Weight 150 lb (68 kg)



VBR6240
STRETCHTRAINER

Dimensions (LxWxH)
60 x 36 x 40 in (152 x 91 x 102 cm)
Weight 55 lb (25 kg)



PLATE LOADED

Glutebuilder® Plate Loaded

Buzz-worthy glute training products

- **PRECISION BIOMECHANICS**

Exact motion paths with smooth, constant resistance ensures effective and efficient workouts.

- **OPTIMAL FIT FOR ALL EXERCISERS**

Multiple adjustment points allow exercisers to find the perfect fit and range of motion.

- **EXERCISE VARIETY**

Innovative plate loaded products that target the glutes, legs, and hips.

[VISIT GLUTEBUILDER »](#)

PRECOR®

GLUTEBUILDER®



CREATE A DYNAMIC GLUTE TRAINING AREA

Glute training is more popular than ever. Enhance your strength training floor with Glutebuilder equipment that stands for quality and innovation. Exclusively available from Precor, these Glutebuilder products were designed with precision biomechanics to target the glutes, legs, and hips.

Glutebuilder® Plate Loaded



GPL0612
HIP THRUST ELITE

Dimensions (LxWxH)

77 x 67 x 51 in (196 x 170 x 130 cm)

Weight 550 lb (249 kg)

Max. Lift Load Capacity 660 lb (300 kg)

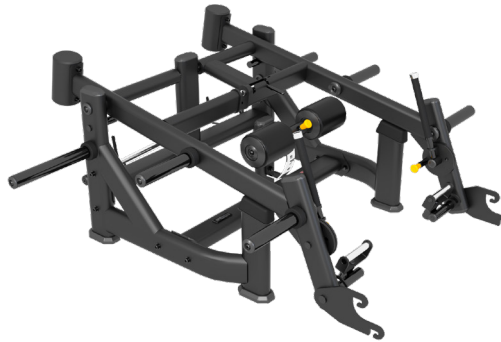

GPL0551
DEADLIFT ELITE

Dimensions (LxWxH)

67 x 74 x 29 in (170 x 188 x 74 cm)

Weight 462 lb (210 kg)

Max. Lift Load Capacity 880 lb (400 kg)



GPL0622
3D MULTI-ABDUCTOR

Dimensions (LxWxH)

72 x 51 x 58 in (183 x 153 x 147 cm)

Weight 330 lb (150 kg)

Max. Lift Load Capacity 440 lb (200 kg)



GPL0617
PENDULUM KICKBACK

Dimensions (LxWxH)

68 x 60 x 55 in (173 x 152 x 140 cm)

Weight 352 lb (160 kg)

Max. Lift Load Capacity 220 lb (100 kg)



GPL0724
DUAL 45 HIP EXTENSION

Dimensions (LxWxH)

61 x 56 x 49 in (155 x 142 x 125 cm)

Weight 418 lb (190 kg)

Max. Lift Load Capacity 220 lb (100 kg)



GPL0363
KNEELING GLUTE ISOLATOR

Dimensions (LxWxH)

65 x 59 x 56 in (165 x 150 x 142 cm)

Weight 484 lb (220 kg)

Max. Lift Load Capacity 220 lb (100 kg)

Glutebuilder® Benches & Racks

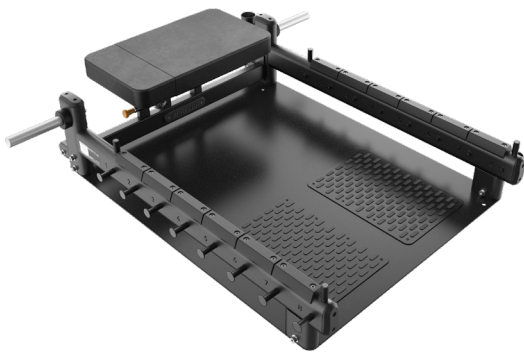

DBR0712
GLUTE BRIDGE BENCH

Dimensions (LxWxH)

59 x 61 x 14 in (150 x 155 x 38 cm)

Weight 236 lb (107 kg)

Max. Lift Load Capacity 550 lb (249 kg)



GBR0107
GLUTEBUILDER BOX PRO

Dimensions (LxWxH)

21 x 23 x 17 in (55 x 60 x 41 cm)

Weight 32 lb (14.5 kg)





STRENGTH

Nike Strength Pro Free Weight and Performance Products

Engineered to the exact specifications of
championship athletes

- **TESTED AND PROVEN BY CHAMPIONSHIP ATHLETES**

Designed for top-tier performance by those who know what it takes to win.

- **BUILT TO LAST**

Precision-machined products that hold up to the toughest workouts.

- **BACKED BY PRECOR**

Single source sales and service you can count on.

- **STRENGTH THAT STANDS OUT**

Iconic design with signature Nike style, built to make an impact.

[VISIT NIKE STRENGTH»](#)

PRECOR®



COMMERCIALLY TESTED, ATHLETE APPROVED

Take Precor workouts to the next level with Nike Strength free weights, a premium line of Nike Strength Pro plates and dumbbells designed for commercial fitness facilities.





Nike Strength



NIKE STRENGTH PRO URETHANE DUMBBELLS

Built to withstand heavy use, making it the ultimate choice for any commercial facility.

Weight Range 5 to 100 lb

Handle Diameter 32 to 34 mm depending on weight

Handle Width 128 mm

Knurling Medium



NIKE DUMBBELLS

Offers both durability and comfort for all your training sessions.

Weight Range 5 to 100 lb (Black/Black), 5-50 lb (Black/White, Grind)

Handle Diameter 32 to 34 mm depending on weight

Handle Width 128 mm

Knurling Medium

Colors Black, White, and Nike Grind*



NIKE STRENGTH PRO URETHANE PLATES

Built to withstand heavy use, making it the ultimate choice for any commercial facility.

Weights 2.5, 5, 10, 25 & 45 lb

Diameter 150 mm to 450 mm depending on weight



NIKE RUBBER BUMPER PLATES

Crafted from premium rubber, they're built to endure countless repetitions.

Weights 10, 15, 25, 35, 45 lb

Diameter 450 mm

Colors Black and Nike Grind*

*Nike Grind, exact color mixtures vary by season



NIKE CHANGE PLATES

A secure, quiet, and durable way to increase weight in small increments.

Weight Range 1.25, 2.5, 5, 10 lb

Thickness 0.5 to 1.1 in (13 to 28 mm) depending on weight

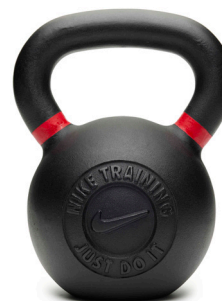

NIKE KETTLEBELLS

Crafted for versatility and built to last, the powder-coated finish ensures a smooth and secure grip.

Weight Range 9 to 88 lb (4 to 40 kg)

Handle Diameter 30 to 40 mm depending on weight

Handle Width 160 to 238 mm depending on weight



NIKE WEIGHT SLED

Designed for a variety of workouts, including push, pull, and drag variations.

Dimensions (LxWxH)

39 x 25 x 37 in (99 x 64 x 94 cm)

Weight 90 lb (41 kg)

Weight Capacity 500 lb (227 kg)

Nike Strength



NIKE STRENGTH SHIELD BARBELL 20K

- **Bar Use** All-Around
- **Bar Weight** 44 lb (20 kg)
- **Internal Components** 4 premium bushings
- **Loadable Sleeve Length** 16.3 in (41.5 cm)
- **Sleeve Diameter** 2 in (5 cm)
- **Bar Length** 86.6 in (220 cm)
- **Distance Between Sleeves** 51.6 in (131 cm)
- **Diameter** 1.12 in (2.85 cm)
- **Knurl** Medium volcano knurl with dual knurl marks
- **Shaft Coating** Cerakote® Coating
- **Tensile Strength** 190,000 PSI
- **Whip** Medium
- **Weight Capacity** 1500 lb (680 kg)



NIKE STRENGTH SHIELD BARBELL 15K

- **Bar Use** All-Around
- **Bar Weight** 33 lb (15 kg)
- **Internal Components** 4 premium bushings
- **Loadable Sleeve Length** 12.6 in (32 cm)
- **Bar Length** 79.1 in (201 cm)
- **Distance Between Sleeves** 51.6 in (131 cm)
- **Diameter** 0.98 in (2.5 cm)
- **Knurl** Medium volcano knurl with dual knurl marks
- **Shaft Coating** Cerakote® Coating
- **Tensile Strength** 190,000 PSI
- **Whip** Medium
- **Weight Capacity** 1500 lb (680 kg)



NIKE 1972 POWER BAR

- **Bar Use** Powerlifting
- **Bar Weight** 44 lb (20 kg)
- **Internal Components** 4 premium bushings
- **Loadable Sleeve Length** 16.3 in (41.5 cm)
- **Bar Length** 86.6 in (220 cm)
- **Distance Between Sleeves** 51.6 in (131 cm)
- **Diameter** 1.14 in (2.9 cm)
- **Knurl** Aggressive mountain knurl with center knurling
- **Shaft Coating** Black Chrome
- **Tensile Strength** 200,000 PSI
- **Whip** Low
- **Weight Capacity** 1500 lb (680 kg)



NIKE STRENGTH SHIELD CURL BAR

- **Bar Use** Curl
- **Bar Weight** 22 lb (10 kg)
- **Internal Components** 2 needle bearings
- **Loadable Sleeve Length** 6.75 in (17 cm)
- **Bar Length** 47.2 in (120 cm)
- **Distance Between Sleeves** 32.2 in (81.7 cm)
- **Diameter** 1.1 in (2.8 cm)
- **Knurl** Aggressive mountain knurl with single knurl marks
- **Shaft Coating** Chrome
- **Weight Capacity** 200 lb (90.7 kg)



STRENGTH

Resolute™ Strength Multi-Stations

Modern. Strong. Modular.

- **FLEXIBLE OPTIONS**

Modularity to meet your needs on Day 1 and on Day 3651.

- **MODERN DESIGN**

Anchor your facility with an eye-catching contemporary design.

- **MODULAR STATIONS**

Five cable-based stations give exercisers total body training options.

- **REIMAGINED STRENGTH**

Thoughtful storage clears the clutter with two dedicated solutions.

[VISIT RESOLUTE MULTI-STATIONS »](#)



RESOLUTE™ STRENGTH MULTI-STATIONS



CONFIGURE YOUR MULTI-STATION»

Resolute™ Strength Multi-Stations



RMS0320
DIP-CHIN ASSIST

Dimensions (LxWxH)
68 x 58 x 94 in (172 x 147 x 237 cm)

Weight 955 lb (433 kg)*

*Weight based on a standard weight stack



RMS0212
TRICEPS PUSHDOWN

Dimensions (LxWxH)
47 x 39 x 94 in (120 x 75 x 237 cm)

Weight 544 lb (246 kg)*

Accessory Rope handle

*Weight based on a standard weight stack



RMS0304
LAT PULLDOWN

Dimensions (LxWxH)
52 x 53 x 94 in (131 x 135 x 237 cm)

Weight 630 lb (286 kg)*

Accessory 48 in Bent traditional lat pull-down handle

*Weight based on a standard weight stack



RMS0302
LOW ROW

Dimensions (LxWxH)
101 x 39 x 94 in (257 x 99 x 237 cm)

Weight 677 lb (307 kg)*

Accessory A-frame style handle

*Weight based on a standard weight stack



RMS0905 + OP3
ADJUSTABLE PULLEY WITH STABILITY ARMS

Dimensions (LxWxH)
 59 x 100 x 94 in (149 x 253 x 237 cm)

Weight 429 lb (195 kg)*

Accessory Rubber coated pull handle and ankle cuff with velcro closure

*Weight based on a standard weight stack

Stations	Accessories	Standard	Heavy
Lat Pulldown	48 in Bent traditional lat pulldown handle	260 lb (118 kg)	340 lb (154 kg)
Low Row	A-frame style handle	260 lb (118 kg)	340 lb (154 kg)
Adjustable Pulley	Rubber coated pull handle and ankle cuff with velcro closure	220 lb (100 kg)	300 lb (136 kg)
Triceps Pushdown	Rope handle	220 lb (100 kg)	300 lb (136 kg)
Dip-Chin Assist		340 lb (154 kg)	

Resolute™ Strength Multi-Stations

Flexible Configurations

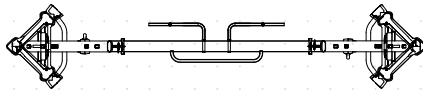

2 Stack Cable Crossover

Dimensions (LxWxH)

20 x 196 x 94 in (51 x 498 x 237 cm)

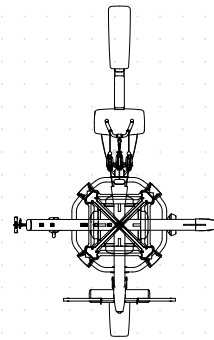

4 Stack

Dimensions (LxWxH)

153 x 96 x 94 in (388 x 243 x 237 cm)

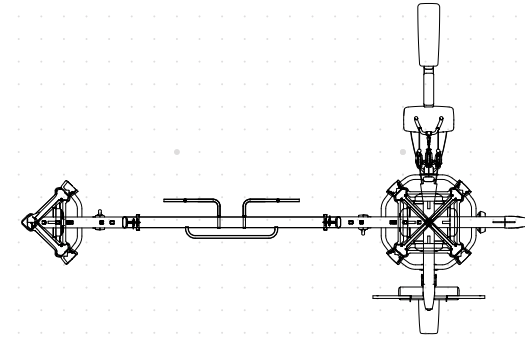

5 Stack

Dimensions (LxWxH)

153 x 237 x 94 in (388 x 601 x 237 cm)

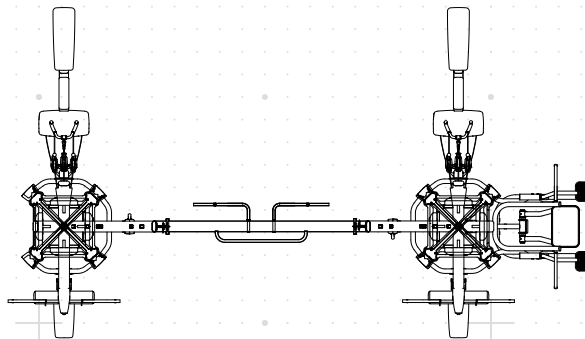

7 Stack

Dimensions (LxWxH)

153 x 277 x 94 in (388 x 703 x 237 cm)

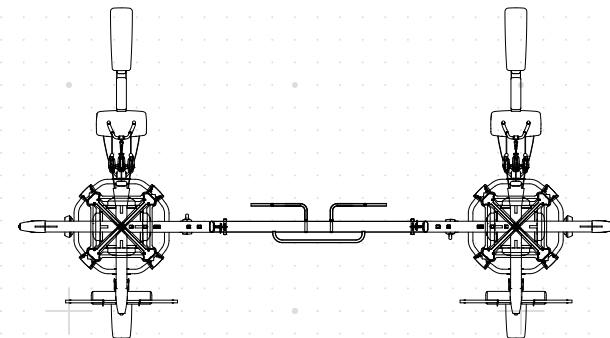

8 Stack

Dimensions (LxWxH)

153 x 270 x 94 in (388 x 685 x 237 cm)

Modular design that gives you control

Choose from a wide selection of stations and configure them to suit your facility's needs. As your facility grows, the modular design makes it easy to add or move stations as needed. The space-saving design ensures that there's plenty of room for lifters, without sacrificing space or usability.

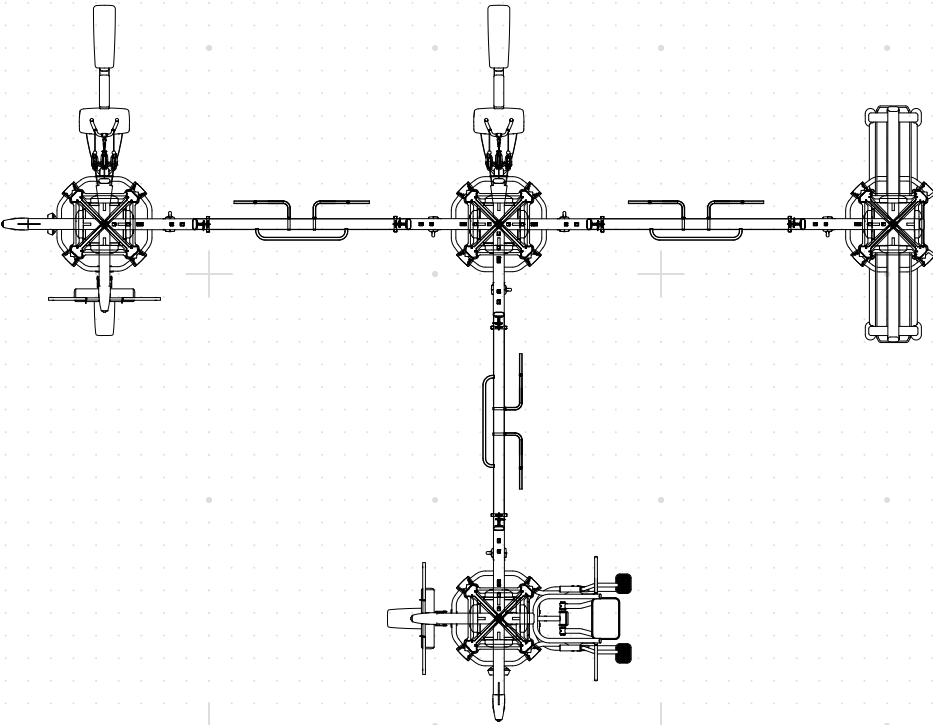

13 Stack with Storage

Dimensions (LxWxH)

153 x 432 x 94 in (388 x 1097 x 237 cm)

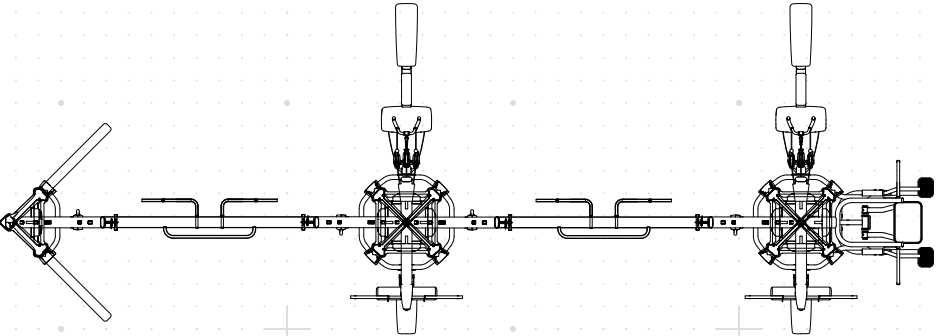

9 Stack

Dimensions (LxWxH)

153 x 433 x 94 in (388 x 1098 x 237 cm)



STRENGTH

Resolute™ Strength Dual Adjustable Pulley

High-performance functional cable trainer

- **ROBUST, SLEEK DESIGN**

Durable enough for the unpredictable demands of your strongest exercisers, with a modern, refined design that conveys strength and simplicity.

- **FUNCTION FIRST**

A comprehensive set of fitness features exercisers are asking for.

- **4:1 CABLE RATIO**

Higher speed training and greater cable travel for more diverse movements.

- **ABOVE AND BEYOND**

Illustrated instructions teach and inspire multiple workouts.



RUD0915 DUAL ADJUSTABLE PULLEY

Dimensions (LxWxH)

54 x 62 x 94 in (137 x 157 x 239 cm)

Weight 672 lb (305 kg)

Weight Stack 2 x 400 lb (2 x 181 kg)

Maximum Workout Area (LxW)

25 x 13 ft (7.6 x 3.9 m)

[VISIT RESOLUTE DUAL ADJUSTABLE PULLEY»](#)



STRENGTH

Vitality™ Strength FTS Glide

Compact functional training system that delivers near-endless options

- **SMALL PACKAGE. BIG PUNCH.**

A serious full-body workout in the compact footprint of a single machine.

- **ONE MACHINE. LIMITLESS POTENTIAL.**

Push, pull, press, curl, and extend for dozens of workouts for every muscle.

- **RELIABLY DURABLE**

Equipment that stands the test of time, backed by industry-best service.

- **EASY TO USE**

Illustrated instructions teach and inspire multiple workouts.

- **CONVENIENT STORAGE**

Thoughtful and functional built-in storage puts accessories within reach.



FTS GLIDE FUNCTIONAL TRAINING SYSTEM

Dimensions (LxWxH)

52 x 58 x 85 in (132 x 147 x 216 cm)

Weight 672 lb (305 kg)

Weight Stack 2 x 200 lb (2 x 91 kg)

[VISIT VITALITY™ FTS GLIDE »](#)



STRENGTH

Functional Training

Premium, robust, and devoted functional training for commercial fitness spaces, powered by BeaverFit®

- **PURPOSE BUILT**

A suite of product options for the functional exercise movements that exercisers expect and enjoy.

- **SPACE EFFICIENT**

Space saving functional training products eliminate clutter and preserve free space.

- **BUILT TO LAST**

Designed, sourced, manufactured and quality-controlled in the US and UK.

- **MILITARY TOUGH**

Trusted by the US military in the toughest training environments for the past decade.

[VISIT FUNCTIONAL TRAINING»](#)

PRECOR®

BEAVERFIT™



MAXIMUM IMPACT AND TRAINING VARIETY

The Precor Functional Training line built by BeaverFit. Each product is expertly adapted for commercial customers to offer next-level durability, premium style, and exercise variety.

Functional Training



FITNESS SINGLE BAY

Dimensions (LxWxH)

71 x 47 x 126 in (180 x 119 x 320 cm)



FITNESS DOUBLE BAY

Dimensions (LxWxH)

130 x 47 x 126 in (330 x 119 x 320 cm)



HOSPITALITY SINGLE BAY

Dimensions (LxWxH)

76 x 49 x 92 in (193 x 124 x 234 cm)



HOSPITALITY DOUBLE BAY

Dimensions (LxWxH)

131 x 49 x 92 in (333 x 125 x 234 cm)



FUNCTIONAL POST

Dimensions (LxWxH)

42 x 26 x 97 in (107 x 66 x 246 cm)



FUNCTIONAL BRIDGE

Dimensions (LxWxH)

183 x 173 x 127 in (465 x 439 x 323 cm)

*Shown with Optional Accessories

Contact your Precor Sales Rep for list of accessories.

CONTACT US»

STRENGTH

Resolute™, Discovery™, and Glutebuilder® Strength Color Options

Frame

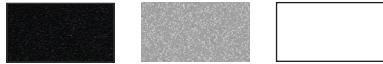

Black Pearl Gloss Metallic Silver Gloss White*

* Custom frame colors are available, subject to minimum order quantities and extended lead times.

* Additional lead time applies.

Shroud



Tungsten

* Custom shroud wraps are available at an additional cost.

Upholstery



Black

Additional Upholstery Options**



Grey Slate American Beauty Candy Apple All Spice Bucksuede



Burgundy Royal Blue Blue Jay Chocolate Hunter Green

* Additional upholstery options may have longer lead times.

* Colors may vary.

** Additional lead time applies.

[VISIT OUR COLOR SELECTOR»](#)





STRENGTH

Vitality™ Strength Color Options

*Vitality™ Strength Selectorized, Benches & Racks, and FTS Glide are limited to the following frame and upholstery color options:

Frame



Black Pearl

Upholstery

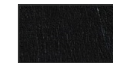

Black

Shroud



Tungsten

Functional Training Color Options*

Frame



Black Pearl



Gloss Metallic



Gloss White**

Custom Color Options*

Frame



RAL 1003



RAL 1018



RAL 2000



RAL 2004



RAL 3000



RAL 3003



RAL 3020



RAL 5002



RAL 5005



RAL 5015



RAL 6002



RAL 6005



RAL 6024



RAL 7004



RAL 7047



RAL 8025

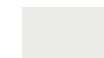

RAL 9003

*Custom frame colors are available, subject to minimum order quantities and extended lead times.

**Additional lead time applies.

WELLNESS

Saunas, light booths, pods, and beds, designed by Wellness USA and exclusively available from Precor

- **3 DECADES OF EXPERIENCE**

Over 40,000 PODs and 60,000 additional systems sold globally over 35 years.

- **PATENTED AND PROVEN**

Leaders in wellness technology with more than 85 patents.

- **BIO-STACKING INNOVATION**

Technologies combine infrared heat, red light, gemstones, oxygen and more to improve results.

- **OPTIONS FOR ALL ENVIRONMENTS**

Pods, Beds, and Saunas for fitness, wellness, and recovery spaces.





>> VISIT
WELLNESS

WELLNESS

Saunas & Light Booth 116

Beds & Pods 118

Saunas & Light Booth



CLUBSTRONG™ SAUNA

- 2, 4, 6, 8 person options
- First infrared sauna built for the commercial market
- Red light chromolight near, mid and far Infrared sauna series
- Bio-stacking technology for faster recovery
- **Dimensions** (see precor.com)



SAUNAWELLNESS™ PRO 5

- 2, 4, 6 person options
- Red light and infrared saunas
- Delivers a full-spectrum experience to enhance overall wellness
- 5 chromolight boxes with 8 color wavelengths
- Bio-stacking technology for faster recovery
- **Dimensions** (see precor.com)

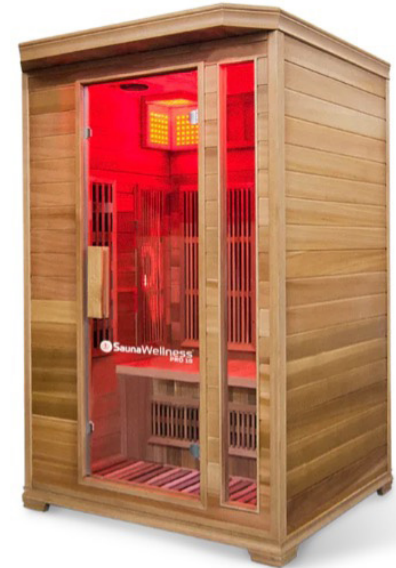

SAUNAWELLNESS™ PRO 10

- 2, 4, 6 person options
- Red light and infrared saunas
- Delivers a full-spectrum experience to enhance overall wellness
- 10 chromolight boxes with 8 color wavelengths
- Bio-stacking technology for faster recovery
- **Dimensions** (see precor.com)



REDFUZION™ REJUVE

- 2 person red light booth, emitting three different red light wave lengths
- 360-degree immersive red light
- 75 red light chromolight boxes with 8 color wavelengths
- **Dimensions** (see precor.com)



Beds & Pods

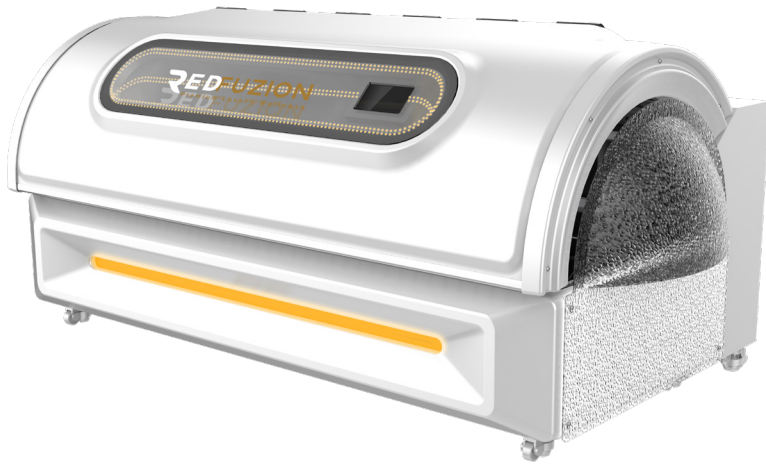

REDFUZION™ PRO-MAX

- Fitness recovery bed
- A wide range of light wavelengths for faster recovery
- Multiple programs for personalized results
- Hyper-oxygen enriched air system promotes relaxation
- **Dimensions (LxWxH)**
77 x 40 x 44 in (199 x 101 x 112 cm)



REDFUZION™ POD

- Infrared wellness dry pod
- Red-light and near-infrared wavelengths for enhanced recovery
- Ergonomic vibration massage for added relaxation
- Hyper-oxygen enriched air system promotes relaxation
- **Dimensions (L x W x H)**
89 x 39 x 90 in (226 x 99 x 228 cm)



CRYOFUZION™ RECOVERY POD

- Thermal recovery wet pod
- Immersive contrast therapy for full-body rejuvenation
- Customizable temperature settings
- Hydrofusion™, infrared heat, steam, and vibration for relaxation
- **Dimensions (L x W x H)**
90 x 36 x 40 in (229 x 90 x 102 cm)



SERVICES

Full-service offerings, tailored to help your brand or community grow

- **COVERED FOR THE LONG HAUL**

Exceptional service from expert technicians to keep your equipment running strong.

- **PROTECTING YOUR INVESTMENT**

Our warranties deliver. With prompt service, certified technicians, and an unmatched customer satisfaction rating.

- **KEEPING YOUR EQUIPMENT IN TIP-TOP SHAPE**

Extend the life of your Precor equipment and minimize downtime. With our preventative maintenance plans, our certified experts will perform regular and thorough cleaning, testing, and calibration.

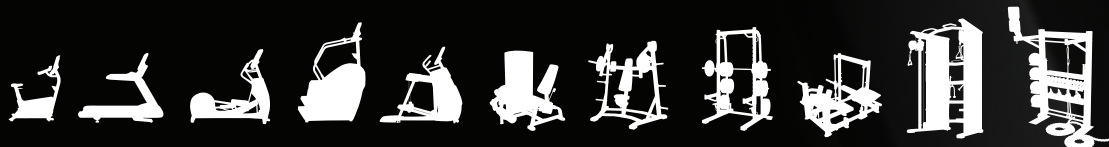



SERVICES

Planning & Design	122
Financing & Leasing	122
Delivery & Installation	123
Service & Support	123
Movement Library	124

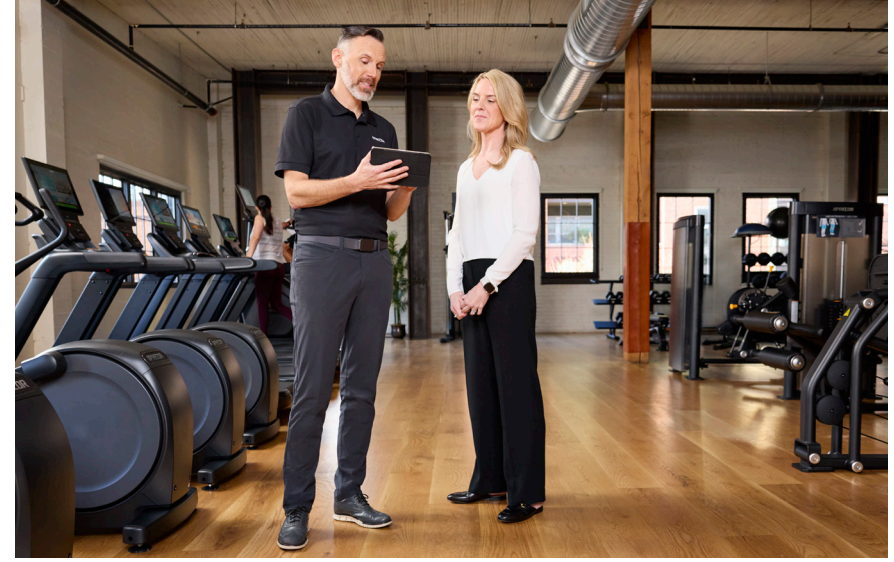

Planning & Design

Our complete, customized approach to design enables you to create a totally unique fitness environment that reflects your membership profile and represents the aspirations of your business.

- Complete design and project management.
- Visualization using 2D and 3D graphics.
- Inspirational use of space and natural light.
- Custom design tailored to individual requirements.
- Access and accessibility as defined by the Americans with Disabilities Act (ADA).
- Audio/visual planning.

[CONTACT SALES »](#)



Financing & Leasing

We realize that every business is unique, which is why we have dedicated, experienced professionals work with you. In strategic partnership with many financial institutions, they'll help assemble financing and leasing packages that meet the needs of your business.

- We have highly knowledgeable and experienced staff to help you make the right decisions for your business.
- We can offer a variety of financing solutions.
- We are committed to providing you with a fast, efficient, and enjoyable financing experience.

[CONTACT SALES »](#)



Delivery & Installation

The moment you place your order, we begin the process of making sure you're completely satisfied. From pre-installation site surveys to equipment training and documentation at installation, our team provides first-class communication and attention to detail.

Our extensive network of equipment and AV installers spans the world. We provide them with ongoing service and technical training, so you can be assured of our high standards for quality installation.

[LEARN MORE »](#)



Service & Support

Our warranties and extended warranties provide comprehensive coverage from the start. Adding preventative maintenance keeps your equipment running in top shape. When your warranty expires, we offer service agreement options that keep your equipment going. Our payment programs take the surprises and guesswork out of your equipment maintenance and repair.

- We guarantee the work performed by our certified technicians.
- 97% of service requests are dispatched within 24 hours.
- Over 90% of our customers rated their service experience as good, very good, or excellent.¹
- Our off-the-shelf parts availability is 97%.

[LEARN MORE »](#)

¹Research conducted by TNS 2015.



Movement Library

Quickly access hundreds of movements and tutorials for Precor cardio, strength, and other functional training equipment to support your training and business.

- English-only video and written materials for the time-sensitive fitness educator
- Includes guidelines for safe set up of equipment and movements
- Content is driven by industry trends and fundamental exercise principles
- Free of charge, 24/7 open-access

[VISIT MOVEMENT LIBRARY »](#)



Trademark Notice

AMT®, Auto Stop, Cardio Theater®, CrossRamp®, Discovery, Dynamic Step Control, EFX®, SCL, Experience Series®, Ground Effects®, Icarian®, Integrated Footplant Technology, IFT, Open Stride, Precor®, PrecorCast, Preva®, Resolute®, StretchTrainer and Vitality are trademarks of Peloton Interactive, Inc.

Beaverfit is a registered trademark of Beaverfit Limited

ClubCom is a registered trademark of ClubCom, LLC

EGYM is a registered trademark of eGym GmbH

Glutebuilder is a registered trademark of Glutebuilder, LLC

Pluto TV is a registered trademark of Pluto, Inc.

Netflix is a registered trademark of Netflix, Inc.

VO2 Media is a registered trademark of VO2 Media Limited

YouTube is a registered trademark of Google LLC.

The Bluetooth® word mark and logos are registered trademarks owned by Bluetooth SIG, Inc. and any use of such marks by Precor is under license.

Other names in this document and all documents included in this catalog may be the trademarks or registered trademarks of their respective owners.

Intellectual Property Notice

Precor is widely recognized for its innovative, award-winning designs of exercise equipment. Precor aggressively seeks U.S. and foreign patents for both the mechanical construction and the visual aspects of its product design. Any party contemplating the use of Precor product designs is hereby forewarned that Precor considers the unauthorised appropriation of its proprietary rights to be a very serious matter. Precor will aggressively pursue all unauthorised appropriation of its proprietary rights.





PRECOR

24309 Snohomish Woodinville Rd
P.O. Box 7202
Woodinville, WA 98072 USA
T: +1 (800) 786-8404
E: info@precor.com
www.precor.com

© Precor Incorporated 2024. The information contained within this catalogue is correct at the time of printing.
Precor reserves the right to make any changes without prior notice.

